

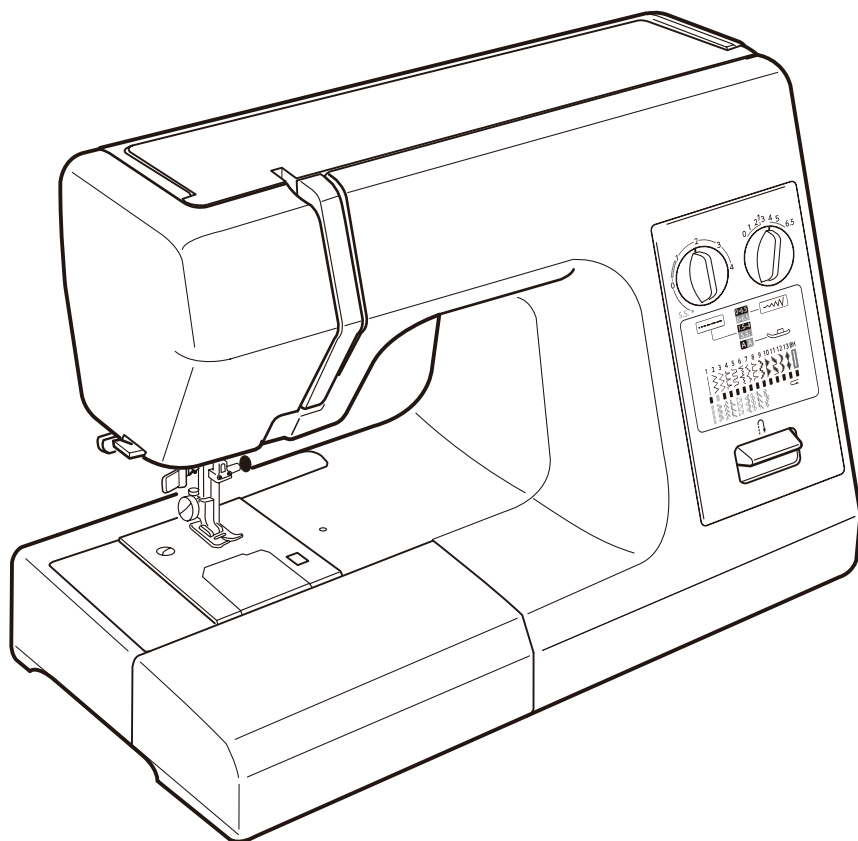

View this machine and more at:

<https://www.thesewingstudio.co.uk>

INSTRUCTION BOOK



IMPORTANT SAFETY INSTRUCTIONS

When using an electrical appliance, basic safety precautions should always be followed, including the following:

This sewing machine is designed and manufactured for household use only.

Read all instructions before using this sewing machine.

DANGER— To reduce the risk of electric shock:

1. An appliance should never be left unattended when plugged in. Always unplug this sewing machine from the electric outlet immediately after using and before cleaning.

WARNING— To reduce the risk of burns, fire, electric shock, or injury to persons:

1. Do not allow to be used as a toy. Close attention is necessary when this sewing machine is used by or near children.
2. Use this appliance only for its intended use as described in this owner's manual. Use only attachments recommended by the manufacturer as contained in this owner's manual.
3. Never operate this sewing machine if it has a damaged cord or plug, if it is not working properly, if it has been dropped or damaged, or dropped into water. Return this sewing machine to the nearest authorized dealer or service center for examination, repair, electrical or mechanical adjustment.
4. Never operate the appliance with any air opening blocked. Keep ventilation openings of this sewing machine and foot controller free from accumulation of lint, dust and loose cloth.
5. Never drop or insert any object into any opening.
6. Do not use outdoors.
7. Do not operate where aerosol (spray) products are being used or where oxygen is being administered.
8. To disconnect, turn all controls to the off ("O") position, then remove plug from outlet.
9. Do not unplug by pulling on cord. To unplug, grasp the plug, not the cord.
10. Keep fingers away from all moving parts. Special care is required around the sewing machine needle and/or cutting blade.
11. Always use the proper needle plate. The wrong plate can cause the needle to break.
12. Do not use bent needles.
13. Do not pull or push fabric while stitching. It may deflect the needle causing it to break.
14. Switch this sewing machine off ("O") when making any adjustment in the needle area, such as threading the needle, changing the needle, threading the bobbin or changing the presser foot, and the like.
15. Always unplug this sewing machine from the electrical outlet when removing covers, lubricating, or when making any other adjustments mentioned in this owner's manual.

SAVE THESE INSTRUCTIONS

For Europe only:

This appliance can be used by children aged from 8 years and above and persons with reduced physical, sensory or mental capabilities or lack of experience and knowledge if they have been given supervision or instruction concerning use of the appliance in a safe way and understand the hazards involved. Children shall not play with the appliance. Cleaning and user maintenance shall not be made by children without supervision.

For outside Europe (except U.S.A and Canada):

This appliance is not intended for use by persons (including children) with reduced physical, sensory or mental capabilities, or lack of experience and knowledge, unless they have been given supervision or instruction concerning use of the appliance by a person responsible for their safety. Children should be supervised to ensure that they do not play with the appliance.



Please note that on disposal, this product must be safely recycled in accordance with relevant National legislation relating to electrical/electronic products. If in doubt please contact your retailer for guidance. (European Union only)

TABLE OF CONTENTS

SECTION I ESSENTIAL PARTS

Names of Parts.....	1
Foot Storage Compartment.....	2
Extension Table (Accessory Storage Box).....	2
Removable Extension Table	3

SECTION II GETTING READY TO SEW

Connecting the Machine to the Power Supply ..	4
Foot Control.....	4
Additional Clearance	5
Pressure Dial.....	5
Dropping the Feed Dogs	5
To Snap On and Snap Off the Presser Foot	6
To Detach and Attach the Foot Holder.....	6
Reverse Stitch Button.....	7
Seam Guide Line.....	7
Changing Needle.....	8
Fabric and Needle Chart	8
Winding the Bobbin	9-11
Horizontal Spool Pin.....	9
Additional Spool Pin	9
Removing the Bobbin.....	9
Threading the Bobbin Winder	10
Inserting the Bobbin	11
Threading the Machine.....	12
Needle Threader	13
Drawing Up Bobbin Thread.....	14
Balanced Thread Tension	15
Manual Thread Tension Adjustment.....	15
Pattern Selector Dial	16
Zigzag Width Dial	16
Stitch Length Dial	16
Variable Needle Position	16

SECTION III BASIC SEWING

Straight Stitch Sewing	17
Changing the Sewing Directions	18
Straight Stitching on Heavy Fabrics.....	18

SECTION IV UTILITY STITCHING

Zigzag Stitching.....	19
Overcasting	19
Overedge Stitch.....	20
Tricot Stitch.....	20
Triple Strength Stitch	21
Sewing Buttons	22
Automatic Buttonhole	23-24
Manual Buttonhole	25
Corded Buttonhole	26
Zipper Application	27-29
Blind Stitch Hemming	30

SECTION V DECORATIVE STITCHING

Decorative Satin Stitch Patterns	31
Stretch Stitch Patterns.....	31
Adjusting Stretch Stitch Balance	32
Smocking.....	32
Quilting	33
Pin Tucking.....	34
Shell Tuck.....	35
Fagoting.....	35
Applique	36
Patchwork.....	36
Twin Needle.....	37

SECTION VI CARE AND MAINTENANCE

Cleaning the Hook Race	38
Trouble Shooting	39-40

SECTION I ESSENTIAL PARTS Names of Parts

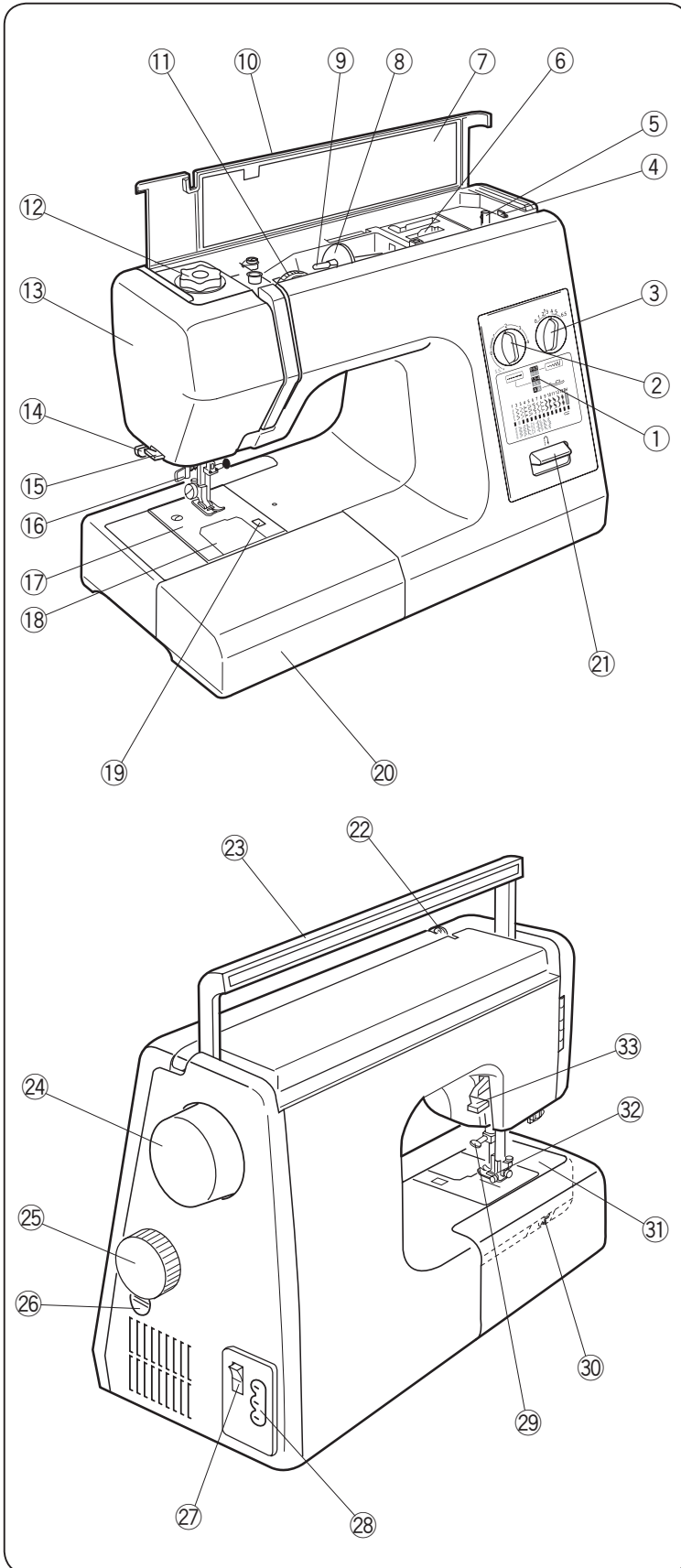

- ① Guide message window
- ② Stitch length dial
- ③ Zigzag width dial
- ④ Bobbin winder stopper
- ⑤ Bobbin winder spindle
- ⑥ Foot storage compartment
- ⑦ Flip-top sewing instruction panel
- ⑧ Spool holder (large)
- ⑨ Spool pin
- ⑩ Top cover
- ⑪ Thread tension dial
- ⑫ Pressure dial
- ⑬ Face plate
- ⑭ Buttonhole lever
- ⑮ Thread cutter
- ⑯ Needle threader
- ⑰ Needle plate
- ⑱ Hook cover plate
- ⑲ Hook cover plate release button
- ⑳ Extension table
(Accessory storage box)
- ㉑ Reverse stitch button

- ㉒ Thread take-up lever
- ㉓ Carrying handle
- ㉔ Handwheel
- ㉕ Pattern selector dial
- ㉖ Feed balance dial
- ㉗ Power switch
- ㉘ Machine socket
- ㉙ Needle clamp screw
- ㉚ Drop feed lever
- ㉛ Free arm
- ㉜ Presser foot
- ㉝ Presser foot lifter

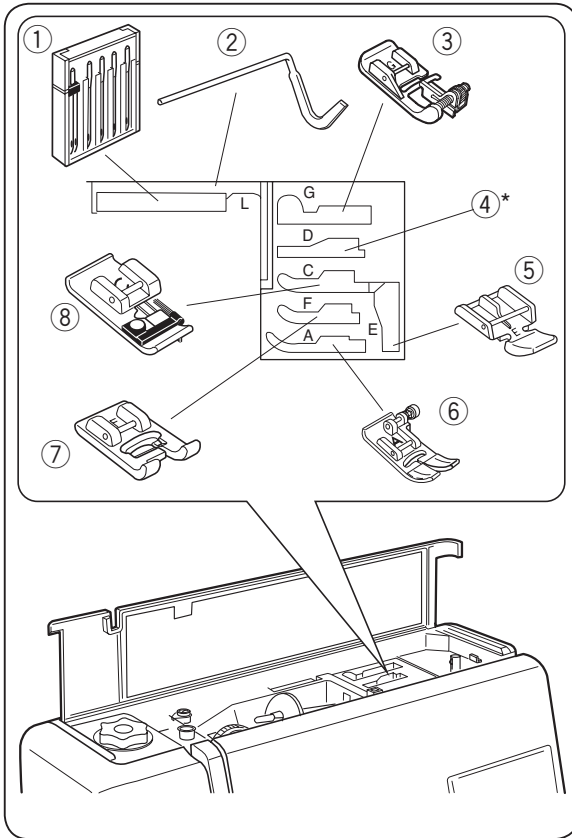

Foot Storage Compartment

Each presser foot and pocket is lettered for easy identification and storage. To achieve optimum sewing results, use the foot recommended for each sewing technique.

- ① Needle case
- ② Quilting guide bar
- ③ Blind stitch hem foot G
- ④ Rolled hem foot D*
- ⑤ Zipper foot E
- ⑥ Zigzag foot A
- ⑦ Satin stitch foot F
- ⑧ Overedge foot C

* Rolled hem foot D is an optional item.

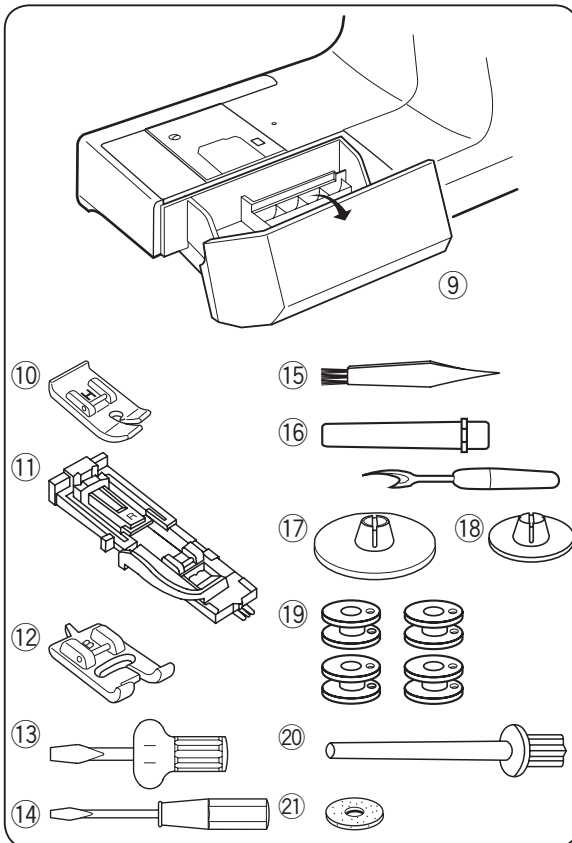

Extension Table (Accessory Storage Box)

Sewing accessories are conveniently located in the extension table.

- ⑨ Extension Table

- ⑩ Straight stitch foot H
- ⑪ Automatic buttonhole foot R
- ⑫ Transparent buttonhole foot B
- ⑬ Screwdriver (large)
- ⑭ Screwdriver (small)
- ⑮ Lint brush
- ⑯ Seam ripper (buttonhole opener)
- ⑰ Spool holder (large) (set on the machine)
- ⑱ Spool holder (small)
- ⑲ Bobbin (4 pcs.) (1 set on the machine)
- ⑳ Extra spool pin
- ㉑ Felt

Removable Extension Table

Extension Table

The extension table provides an extended sewing area and can be removed for free-arm sewing.

- ① Extension table
- ② Free-arm

To detach:

Draw the table out to the left.

To attach:

Slide the table on the base and push the table to the right.

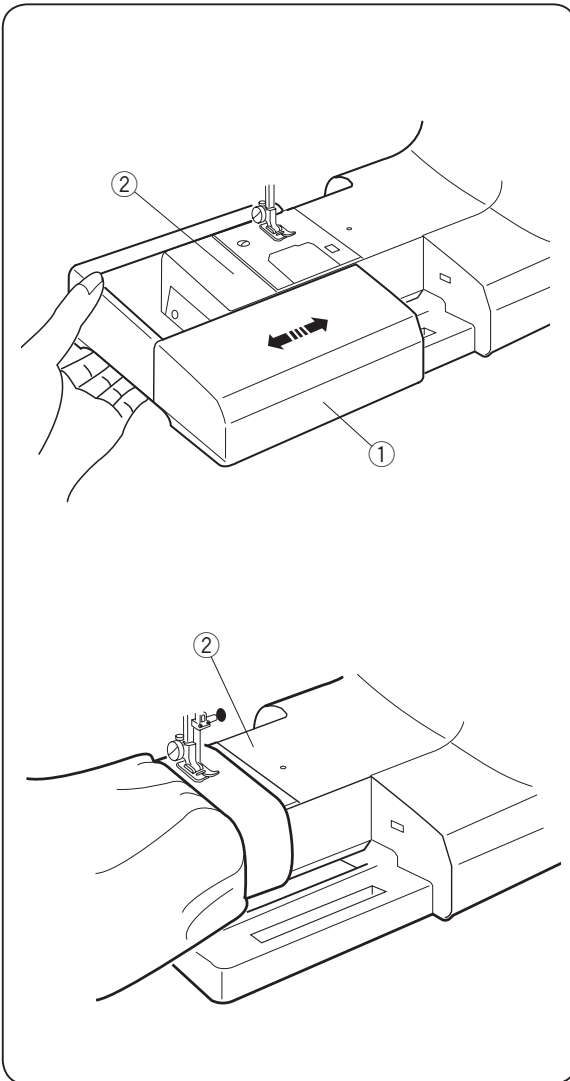

Free-arm sewing

Free-arm sewing is used for stitching sleeves, waistbands, pant legs or any other tubular garments.

It is also useful for darning socks or mending knees or elbows.

- ② Free-arm

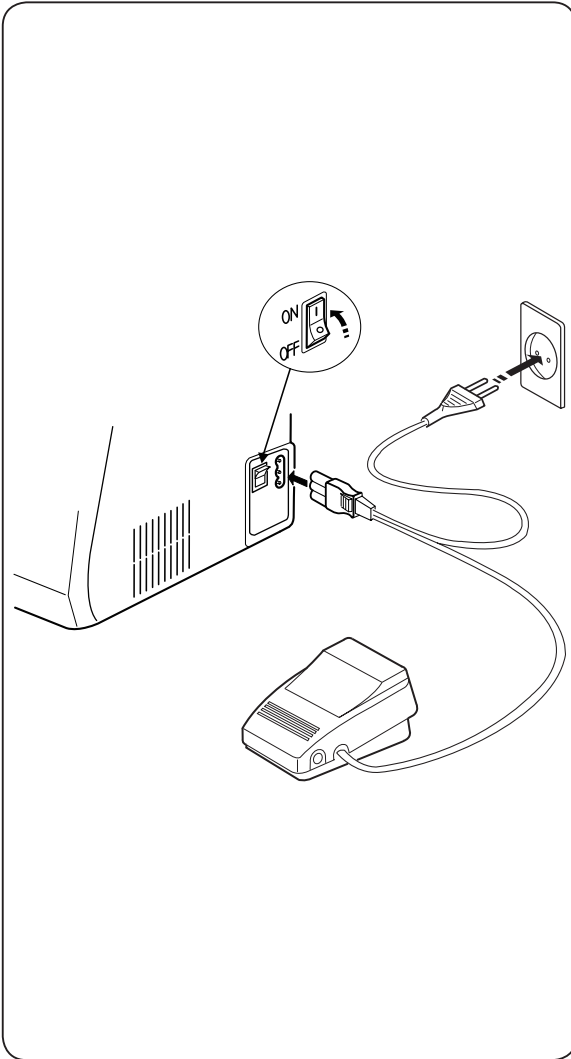

SECTION II GETTING READY TO SEW

Connecting the Machine to the Power Supply

Before connecting the power, make sure the voltage and frequency of your electrical power conform to the machine.

Switch off the power, fit the nonreversible plug into the machine socket and plug the machine into the power supply.

Switch on the power.

While in operation, always keep your eyes on the sewing area, and do not touch any moving parts such as the thread take-up lever, handwheel or needle.

Always turn off the power switch and unplug from the power supply:

- when leaving the machine unattended.
- when attaching or removing parts.
- when cleaning the machine.

Do not place anything on the foot control, otherwise the machine will run inadvertently.

Operating Instructions:

The symbol "O" of a switch indicates the "off" position of a switch.

To reduce the risk of electrical shock, this plug is intended to fit in a polarized outlet only one way. If it does not fit fully in the outlet, reverse the plug. If it still does not fit, contact a qualified electrician to install the proper outlet.

Do not modify the plug in any way.

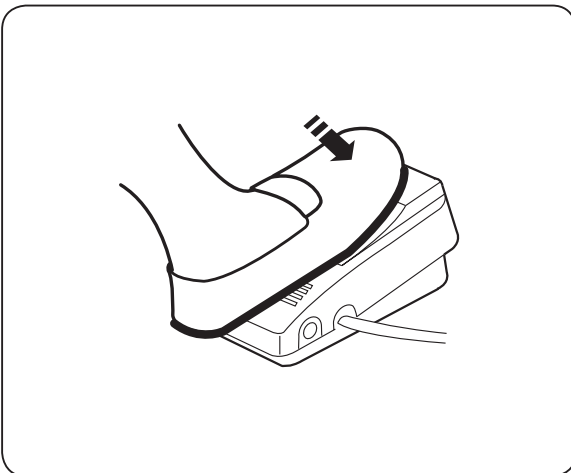

Foot Control

Sewing speed can be varied by the foot control. The harder you press on the control, the faster the machine runs.

Set the speed range switch

Sewing speed range can be varied by the control which is located on foot control.

For HIGH speed range, set the switch at "HIGH" mark.

For LOW speed range, set the switch at "LOW" mark.

* Do not move the switch when machine is running.

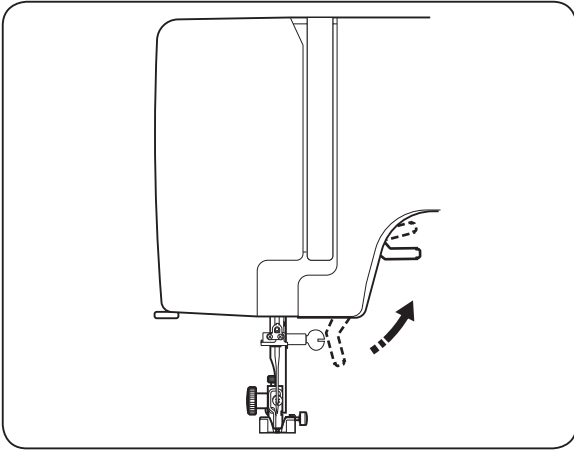

Additional Clearance

The presser foot can be raised higher for additional clearance.

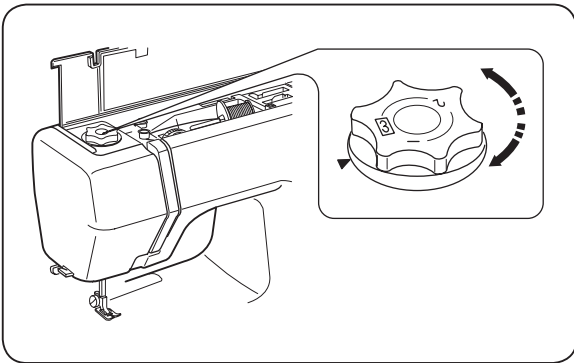

Pressure Dial

The pressure dial should be set at “3” for regular sewing. Reduce the pressure to “2” for appliques. Set the pressure to “1” when sewing chiffon, lace, organdy and other fine fabrics. Velours and knits with a lot of stretch may also require a “1” setting.

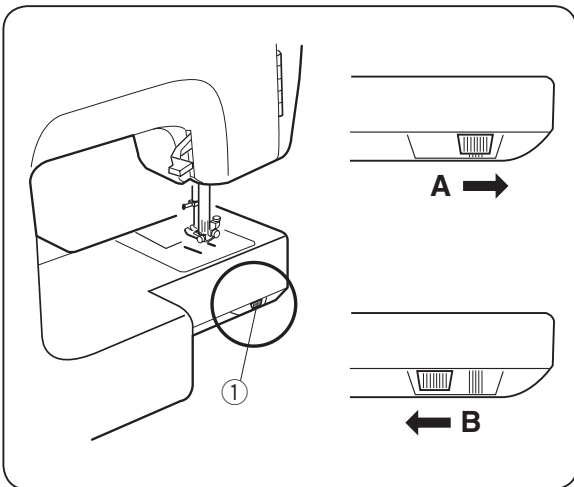

Dropping the Feed Dogs

Drop feed lever is located underneath of free arm bed.

① Drop feed lever

A: To raise the feed dogs, push the lever to the direction of arrow as illustrated.

B: For dropping the feed dogs, push the lever to the direction of arrow as illustrated.

* Feed dogs must always be up for normal sewing.

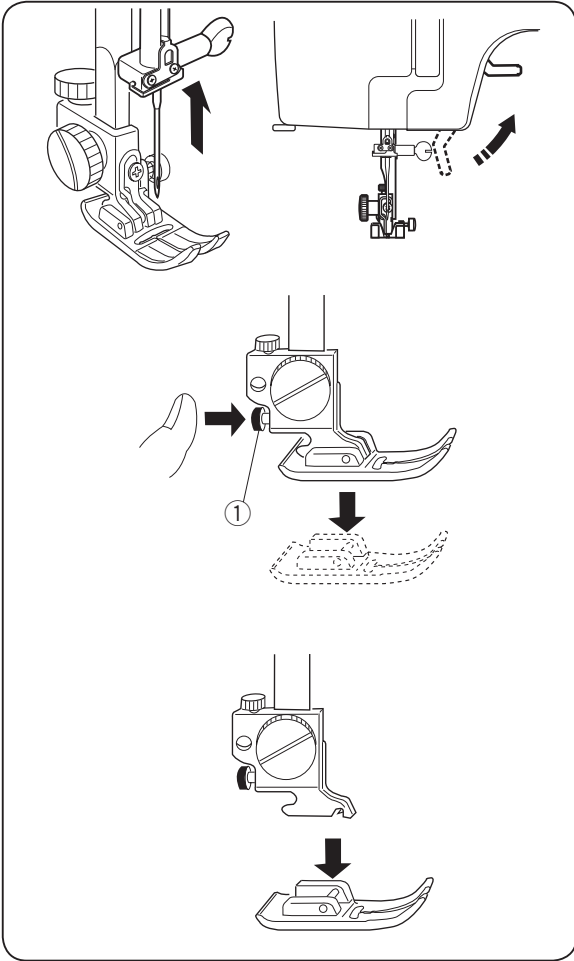

To Snap On and Snap Off the Presser Foot



CAUTION:

Turn the power switch off before replacing the presser foot.

To snap off

Turn the handwheel toward you to raise the needle to its highest position. Raise the presser foot.

Press the red button on the back of the foot holder. The presser foot will drop off.

- ① Red button

To snap on

When attaching the presser foot, the pressure dial should always be at position "3". Place the presser foot so the pin on the foot lies just under the groove of the foot holder. Lower the foot holder to lock the foot in place.

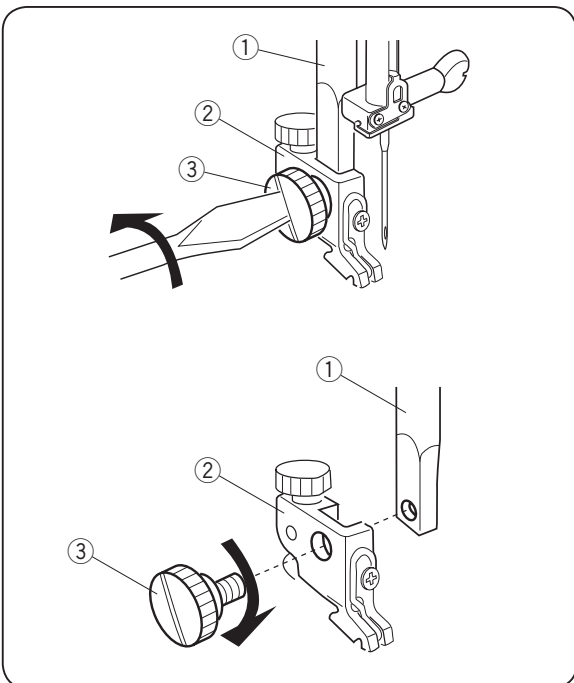

To Detach and Attach the Foot Holder

To Detach

Remove the thumbscrew by turning the screw counter-clockwise with the screwdriver.

- ① Presser bar
- ② Foot holder
- ③ Thumbscrew

To Attach

Align the hole in the foot holder with the threaded hole in the presser bar and fit the foot holder screw into the hole. Tighten the screw by turning it clockwise.

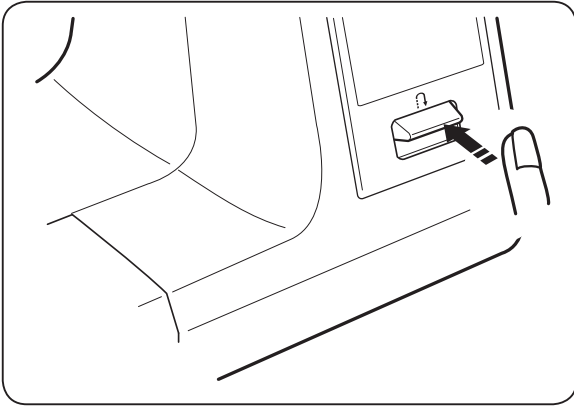

Reverse Stitch Button

As long as you keep the reverse stitch button depressed, the machine sews backwards.

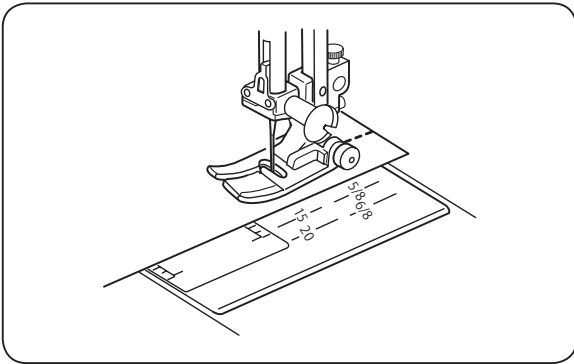

Seam Guide Line

The numbers on the needle plate indicate the distance between the left needle position and the line.

The numbers in the front indicate in millimeters.
The numbers in the back indicate in inches.

Changing Needle



CAUTION:

Turn the power switch off before replacing the needle.

Raise the needle by turning the handwheel toward you and lower the presser foot. Turn off the power switch.

Loosen the needle clamp screw and remove the needle from the clamp.

① Needle clamp screw

Insert a new needle into the needle clamp with the flat side of the needle to the rear. When inserting the needle into the needle clamp, push it up against the stopper pin and tighten the needle clamp screw firmly with a screwdriver.

② Flat side

③ Stopper pin

To check needle straightness, place the flat side of the needle onto something flat (a needle plate, glass etc.)

The gap between the needle and the flat surface should be consistent.

Never use a blunt needle.

④ Gap

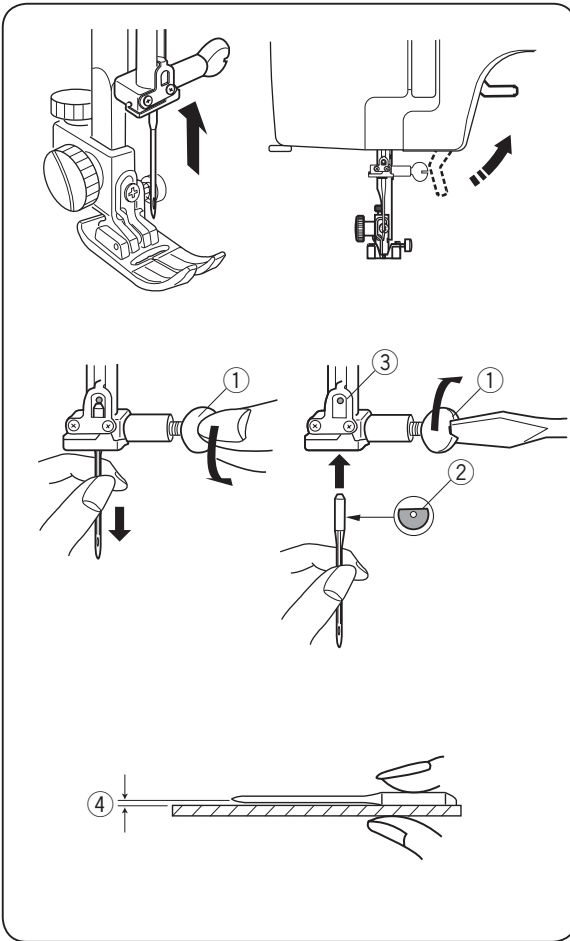

Fabric		Thread	Needle
Fine	Lawn	Silk #80-100	#9/65-11/75 Blue tip needle
	Georgette	Cotton #80-100	
	Tricot	Synthetic #80-100	
Medium	Sheeting	Silk #50	#11/75-14/90 Red tip needle
	Jersey	Cotton #50-80	
	Wool	Synthetic #50-80	
	Knit		
Heavy weight	Denim	Silk #30-50	#14/90-16/100
	Tweed	Cotton #40-50	
	Coating	Synthetic #40-50	
	Quilting		

Fabric and Needle Chart

- For general sewing, use needle size #11/75 or #14/90.
- Fine threads and needles should be used for sewing fine fabrics.
- In general, use the same thread for both needle and bobbin.
- Use a blue tip needle for sewing fine fabrics, stretch fabrics and buttonholes to prevent skipped stitches.
- Use a stabilizer or interface for stretch or fine fabrics to prevent seam puckering.
- Always test the thread and needle size on a small piece of the same fabric you will use for actual sewing.

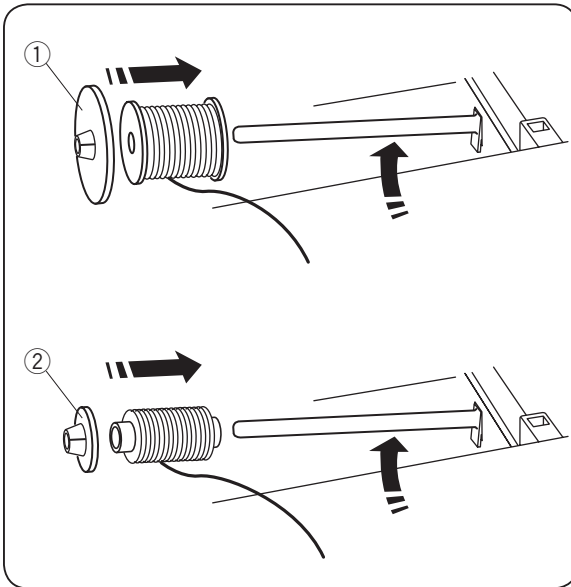

Winding the Bobbin

Horizontal Spool Pin

Lift up the spool pin. Place the spool of thread on the spool with the thread coming off the spool as shown.

Attach the large spool holder pressing it firmly against the thread spool.

- ① Large spool holder

* The small spool holder is used with narrow or small thread spools.

- ② Small spool holder

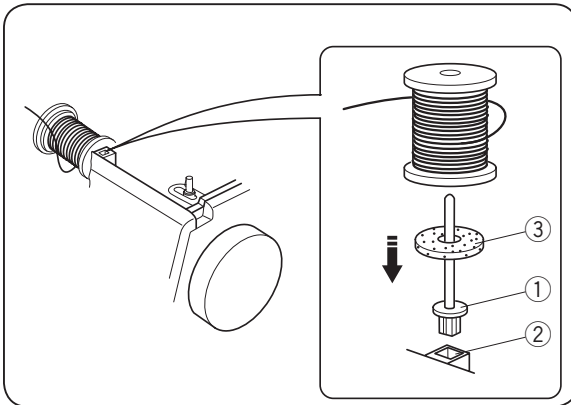

Additional Spool Pin

The additional spool pin is used to wind extra bobbins without unthreading the machine.

The additional spool pin is also for twin needle sewing.

To use, insert the additional spool pin in the hole. Place the felt and the spool on the pin.

- ① Additional spool pin
- ② Hole
- ③ Felt

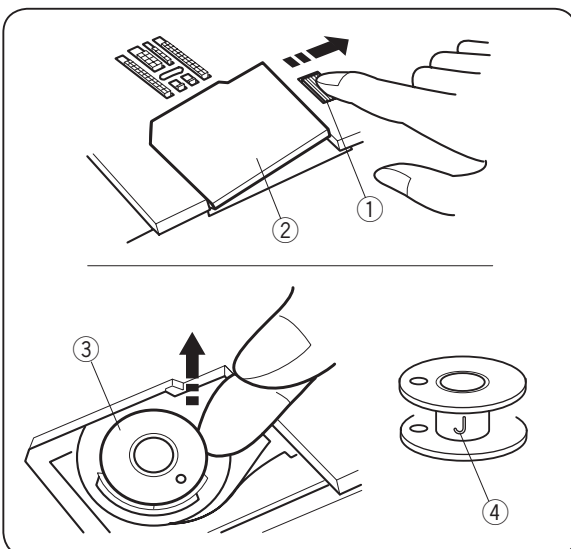

Removing the Bobbin

Gently slide the hook cover plate release button to the right, and remove the hook cover plate.

Lift out the bobbin.

- ① Hook cover plate release button
- ② Hook cover plate
- ③ Bobbin

NOTE:

Use the "J" plastic bobbins for horizontal hook (marked with "J" ④). Using other bobbins, such as pre-wound paper bobbins, may cause stitching problems and/ or damage to the bobbin holder.

Threading the Bobbin Winder

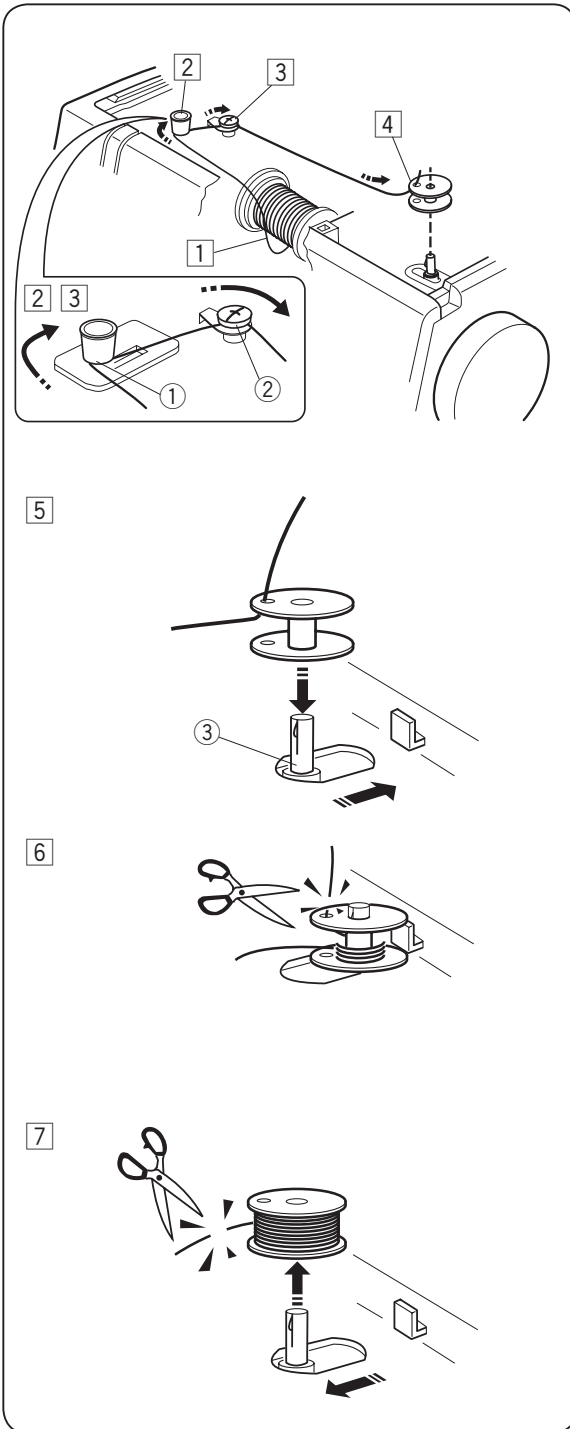

- 1 Draw the thread from the spool.
- 2 Guide the thread around the thread guide.
 - 1 Thread guide
- 3 Guide the thread around the bobbin winder thread guide.
 - 2 Bobbin winder thread guide
- 4 Pass the thread through the hole in the top of the bobbin from the inside to the outside.
- 5 Put the bobbin on the bobbin winder spindle, and push it to the right.
 - 3 Bobbin winder spindle
- 6 With the free end of the thread held in your hand, depress the foot control. Stop the machine when it has made a few turns, and cut the thread close to the hole in the bobbin. Depress the foot control again. When the bobbin is fully wound, it will stop automatically.
- 7 Return the bobbin winder to its original position by moving the spindle to the left, and cut the thread as shown.

Inserting the Bobbin

- 1 Place the bobbin in the bobbin holder with the thread running counter-clockwise.

① Bobbin holder

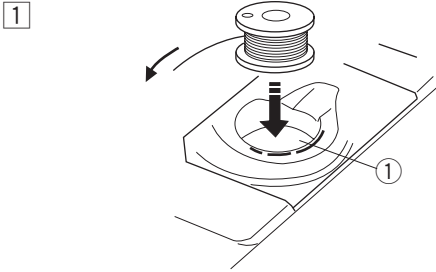

- 2 Guide the thread into the notch A on the front side of the bobbin holder. Draw the thread to the left sliding it between the tension spring blades.

② Notch A

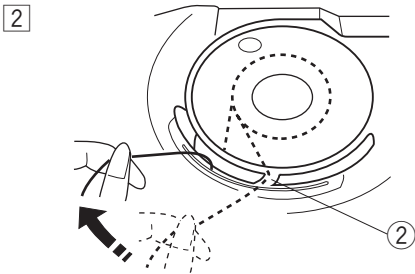

- 3 Continue to draw the thread lightly until the thread slips into notch B.

③ Notch B

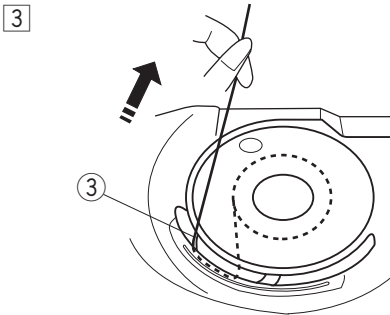

- 4 Pull out about 15 cm (6") of thread and attach the hook cover plate.

④ Hook cover plate

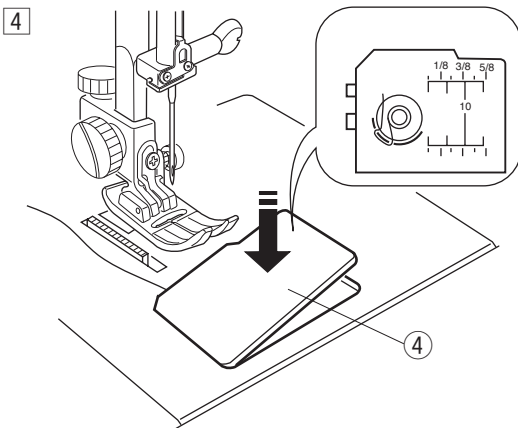

Threading the Machine

Raise the take-up lever to its highest position by turning the handwheel toward you.

Raise the presser foot with the presser foot lifter and thread in the order from 1 to 6.

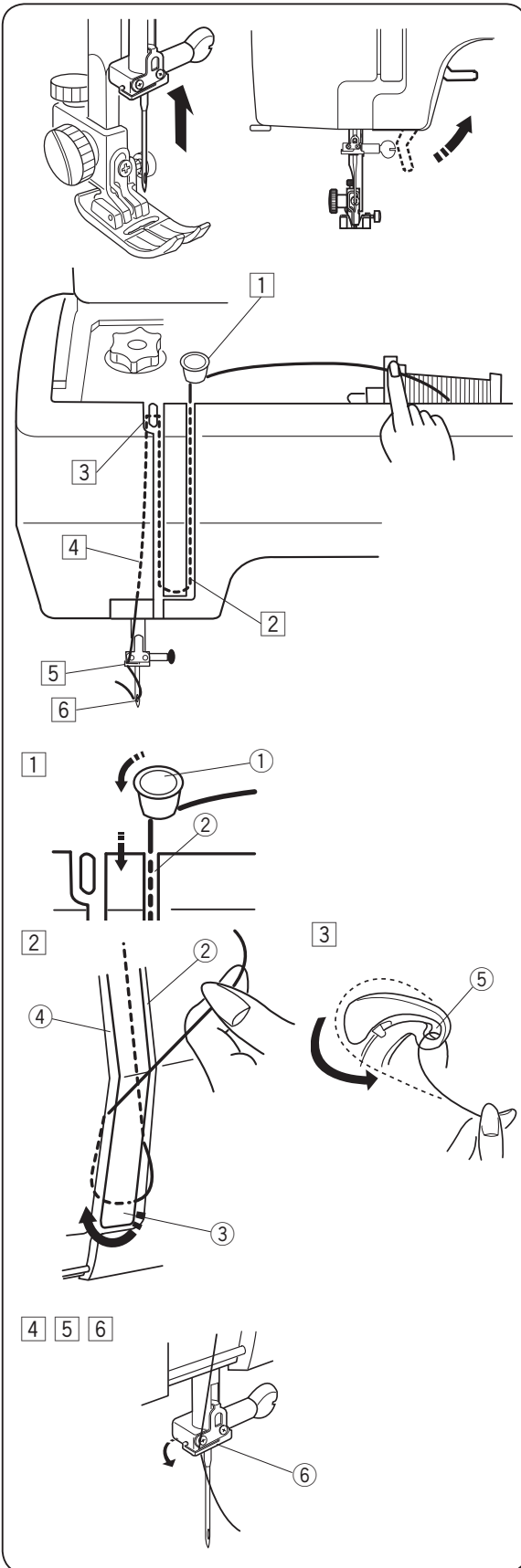

1 Lead the thread from the spool and pass it through the thread guide. Then draw it down along the right channel.

- ① Thread guide
- ② Right channel

2 Draw the thread down along the right channel and around the bottom of the thread guide plate. Pull the thread up along the left channel.

- ② Right channel
- ③ Thread guide plate
- ④ Left channel

3 While holding the thread at the spool, firmly draw the thread up and to the back of the take-up lever. Draw the thread forward to slip it into the eye of the take-up lever.

- ⑤ Eye of the take-up lever

4 Then guide it down along the left channel.

5 Slide the thread from the left behind the needle bar thread guide. Thread the needle.

- ⑥ Needle bar thread guide

6 Thread the needle with the needle threader (refer to the next page).

Needle Threader

1

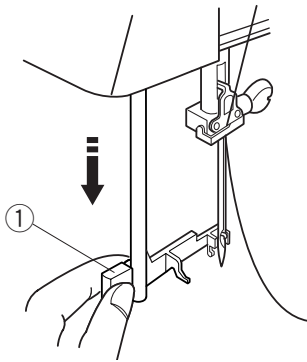

- 1 Lower the presser foot. Raise the needle to its highest position. Pull down the needle threader knob as far as it will go.

① Threader knob

2

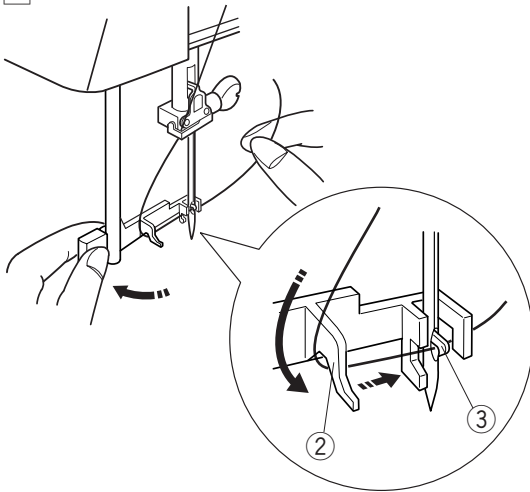

- 2 Turn the knob in the direction of the arrow in the illustration, then insert hook into the needle eye. The hook comes out through the needle eye from behind. Paying close attention to the needle point, draw the thread around the guide and under the hook.

② Guide

③ Hook

3

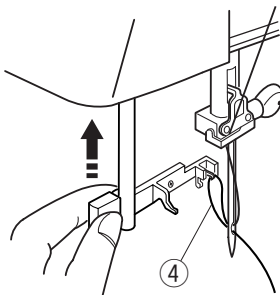

- 3 Turn the knob in the direction of the arrow in the illustration, drawing the thread loop through the needle. Gently let the threader goes up to pull the thread loop up.

④ Thread loop

4

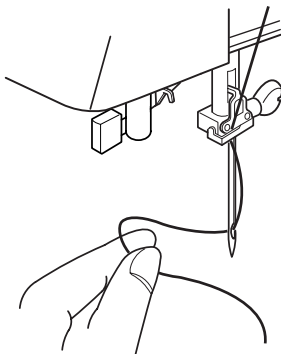

- 4 Pull the thread through the needle eye.

NOTE:

- The needle threader can be used with a #11 to #16 needle or a blue tipped needle. Thread size 50 to 90 should also work well.
- The needle threader cannot be used for a twin needle.

Drawing Up Bobbin Thread

- 1 Raise the presser foot and hold the needle thread lightly with your left hand.

① Needle thread

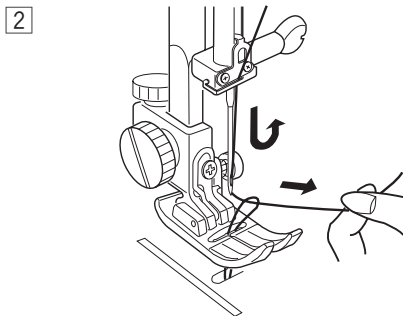
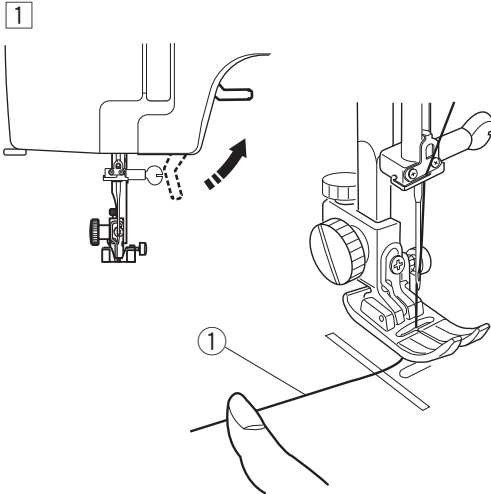

- 2 Turn the handwheel slowly towards you with your right hand until the needle goes down and continue turning handwheel until the take-up lever is at its highest position. Lightly draw up the needle thread forming a loop of bobbin thread.

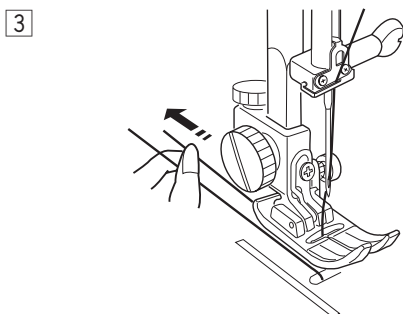

- 3 Pull 15 cm (6") of both threads back and under the presser foot.

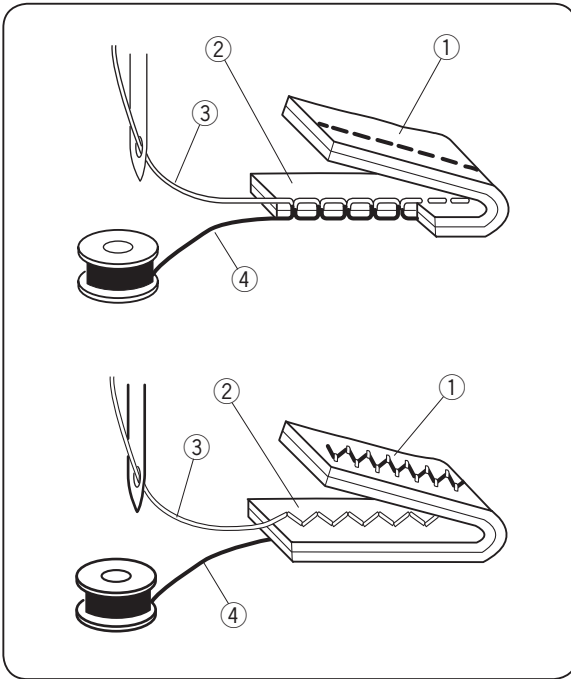

Balanced Thread Tension

For straight stitch sewing, both needle and bobbin threads will join at the middle of the fabrics.

- ① Wrong side of fabric
- ② Right side of fabric
- ③ Needle thread
- ④ Bobbin thread

To obtain better zigzag stitches, the needle thread tension should be slightly weaker than in the case of straight sewing.

The needle thread should appear slightly on the reverse side of the fabric.

- ① Wrong side of fabric
- ② Right side of fabric
- ③ Needle thread
- ④ Bobbin thread

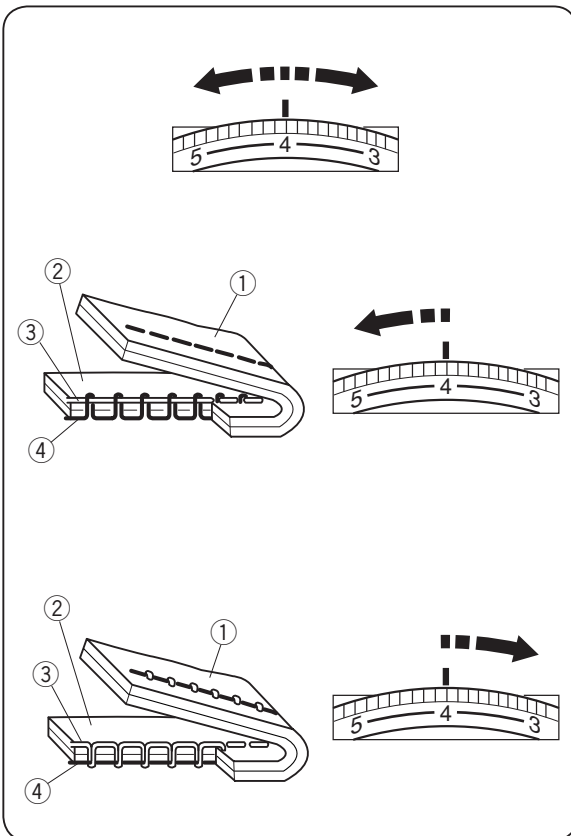

Manual Thread Tension Adjustment

Set the desired number of the thread tension dial at setting mark.

You may also need to adjust tension manually depending on the sewing conditions such as the type of fabric and number of layers.

If the needle thread is too tight, the bobbin thread appears on the right side of the fabric.

- ① Wrong side of fabric
- ② Right side of fabric
- ③ Needle thread
- ④ Bobbin thread

Turn the thread tension dial to a lower number to decrease the thread tension.

If the needle thread is too loose, the needle thread loops on the underside of the fabric.

- ① Wrong side of fabric
- ② Right side of fabric
- ③ Needle thread
- ④ Bobbin thread

Turn the thread tension dial to a higher number to increase the thread tension.

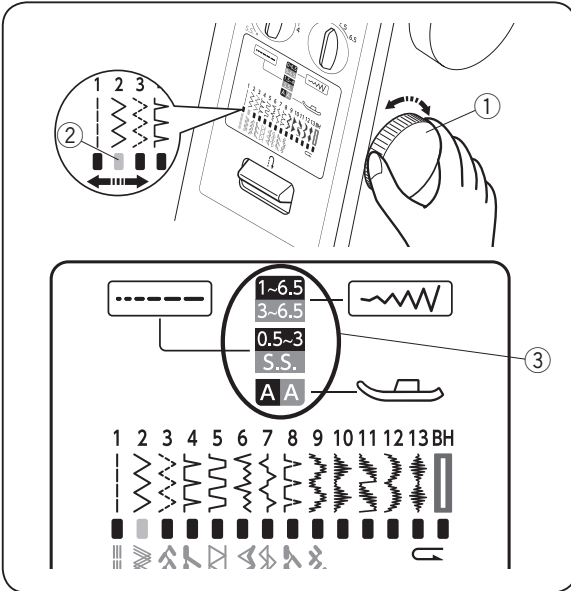

Pattern Selector Dial

Select the pattern by turning the pattern selector dial and the red signal shows the selected pattern.

- ① Pattern selector dial
- ② Red signal

* Raise the needle above the fabrics and presser foot when you turn the pattern selector dial.

Suitable width, stitch length and foot are shown in the guide message window.

- ③ Guide message window

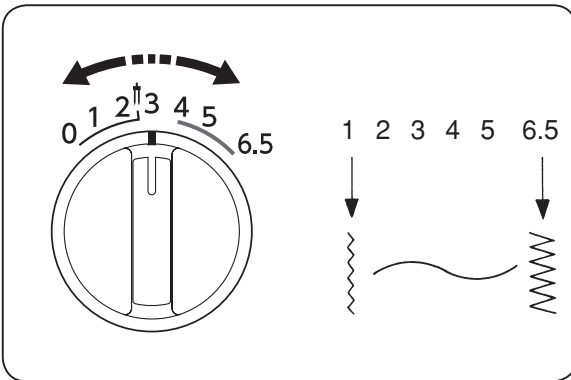

Zigzag Width Dial

Higher the number, wider the stitch width.

This machine will sew the maximum 6.5mm (1/4") wide zigzag.

The ↑ mark shows the adjustment range when using the twin needle. The red zone is the appropriate adjustment range for buttonhole sewing.

NOTE:

Raise the needle above the fabrics when you set the stitch width.

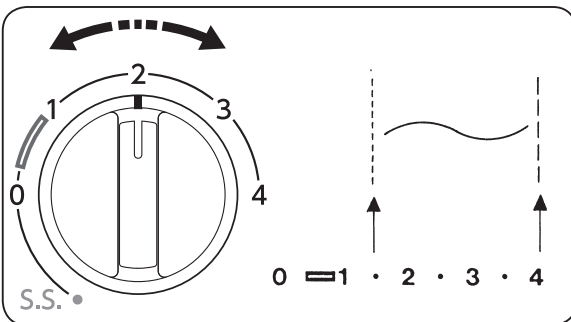

Stitch Length Dial

The higher the number, the longer the stitch length.

You can select the suitable stitch length for fabrics that you plan to sew.

NOTE:

Stitch length is automatically set for stretch stitch pattern on pattern number 9 to 13.

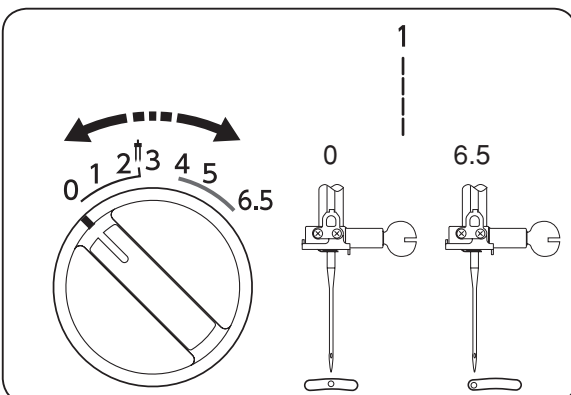

Variable Needle Position

When pattern number 1 is selected, you can move the needle between center and left needle positions.

SECTION III BASIC SEWING

Straight Stitch Sewing

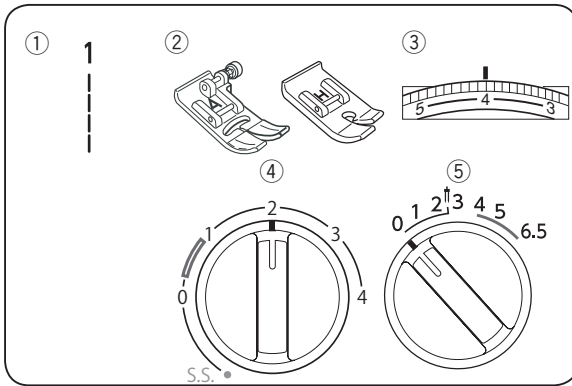

- ① Pattern selector: 1
- ② Presser foot: Zigzag foot A or straight stitch foot H
- ③ Thread tension: 2-6
- ④ Stitch length: 1.5-4
- ⑤ Stitch width: 0 or 6.5

* Use straight stitch foot for exclusively for straight stitching with center needle position.

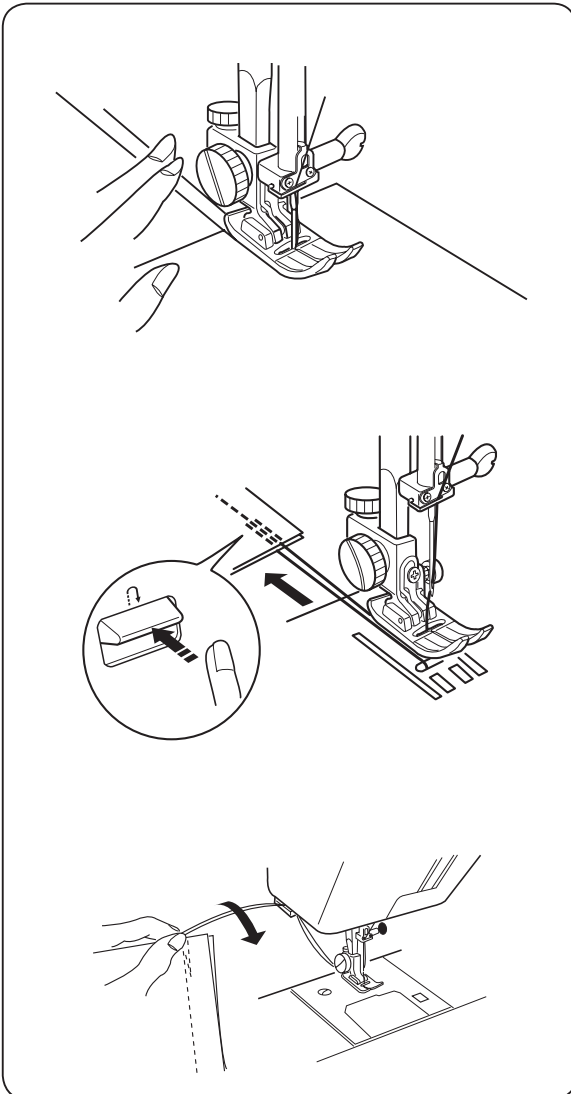

Raise the presser foot and position the fabric next to a stitching guide line on the needle plate.

Lower the presser foot and smooth the threads toward the back. Depress the foot control.

Gently guide the fabric along the guide line letting the fabric feed naturally.

For fastening the ends of seams, press the reverse stitch button and sew several reverse stitches.

Raise the presser foot and remove the fabric, drawing the threads to the back.

The threads are cut the proper length for starting the next seam.

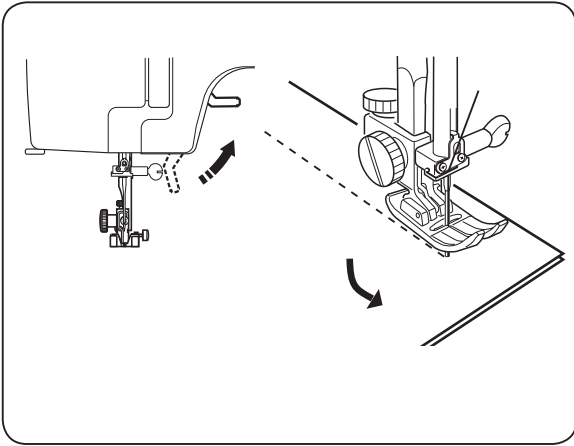

Changing the Sewing Directions

Stop the machine and bring the needle down into the fabric by turning the handwheel. Raise the presser foot.

Pivot the fabric around the needle to change sewing direction as desired. Lower the presser foot.

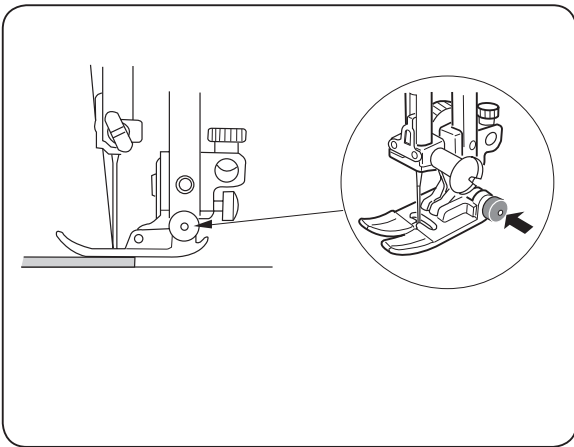

Straight Stitching on Heavy Fabrics

Lower the needle into the fabric at the point where you wish to start sewing. Press the small black button on the zigzag foot with your left hand to “lock” the presser foot to the fabric.

Lower the presser foot with your right hand, keeping pressure on the black button with your left hand.

Release the black button and start sewing.

SECTION IV UTILITY STITCHING

Zigzag Stitching

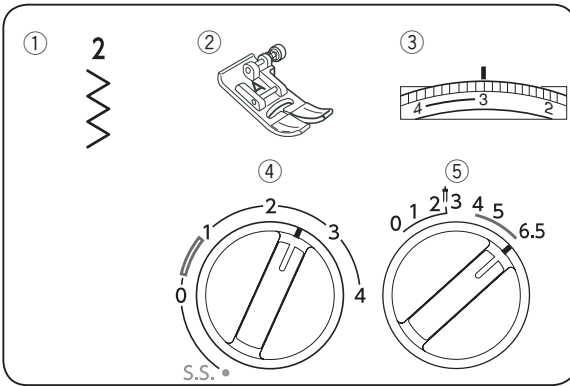

- ① Pattern selector: 2
- ② Presser foot: Zigzag foot A
- ③ Thread tension: 2–5
- ④ Stitch length: 0.5–3
- ⑤ Stitch width: 1–6.5

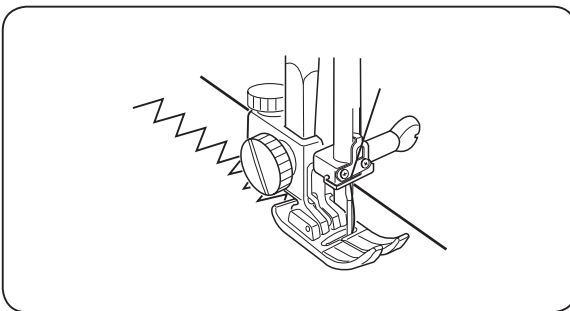

Simple zigzag stitch is widely used for overcasting, applique, sewing on buttons, etc.

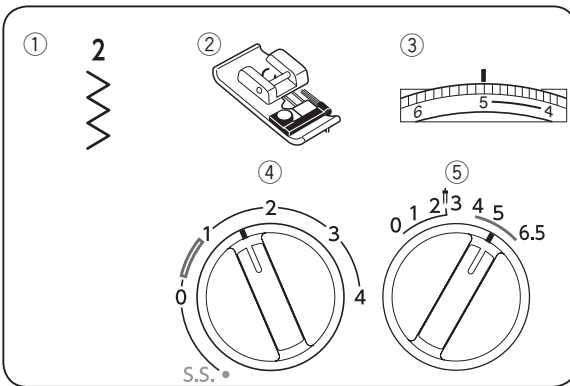

Overcasting

- ① Pattern selector: 2
- ② Presser foot: Overedge foot C
- ③ Thread tension: 3–7
- ④ Stitch length: 1–2
- ⑤ Stitch width: 5–6.5

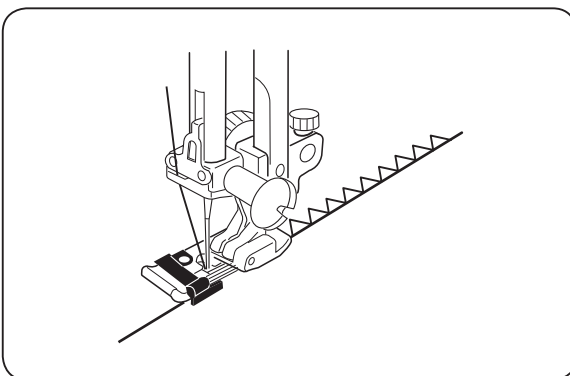

This type of stitch is used on the seam allowance to prevent fabrics from fraying at raw edges. It can be used to finish a hem edge. Place the edge of the fabric next to the black prong of overedge foot C.

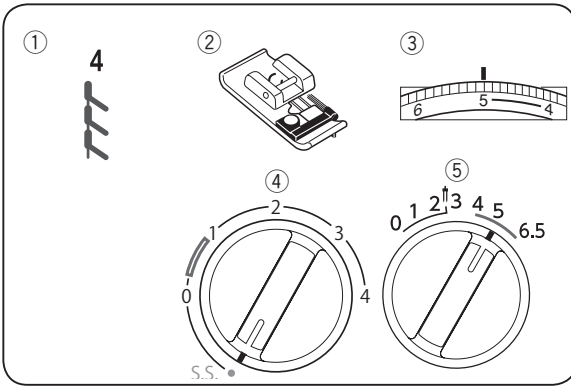

Overedge Stitch

- ① Pattern selector: 4
- ② Presser foot: Overedge foot C
- ③ Thread tension: 3–7
- ④ Stitch length: S.S.
- ⑤ Stitch width: 5

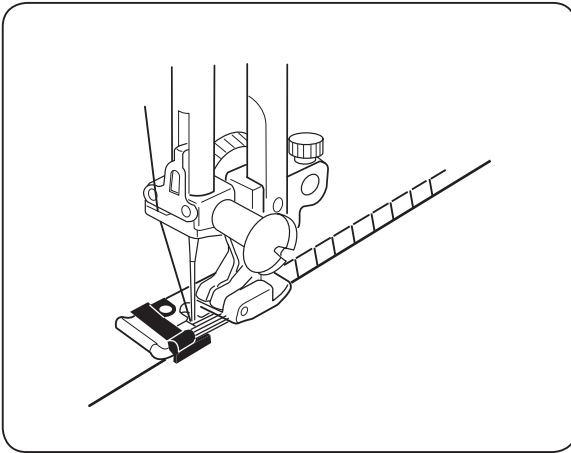

Place the edge of the fabric next to the black prong of foot. The wires on this foot prevent light weight fabric from rolling and creating a ridge. The black prong guides your sewing so the needle falls off the fabric wrapping the threads around the edge to stop raveling.

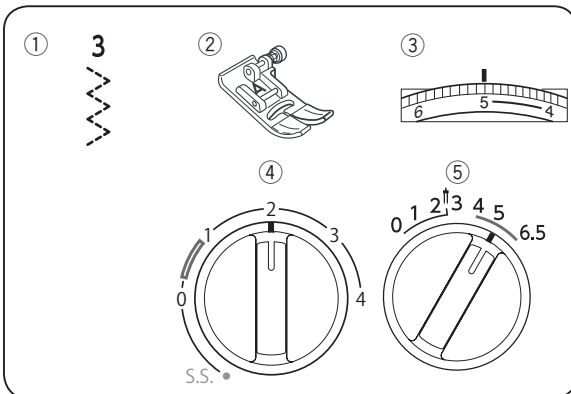

Tricot Stitch

- ① Pattern selector: 3
- ② Presser foot: Zigzag foot A
- ③ Thread tension: 3–6
- ④ Stitch length: 0.5–2
- ⑤ Stitch width: 3–6.5

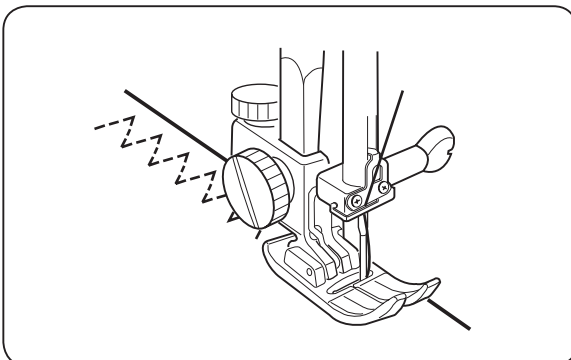

Place the fabric under the presser foot so that the edge will be slightly inside the right hand side of the presser foot. Guide the work so the right hand stitches fall at the edge of the fabric.

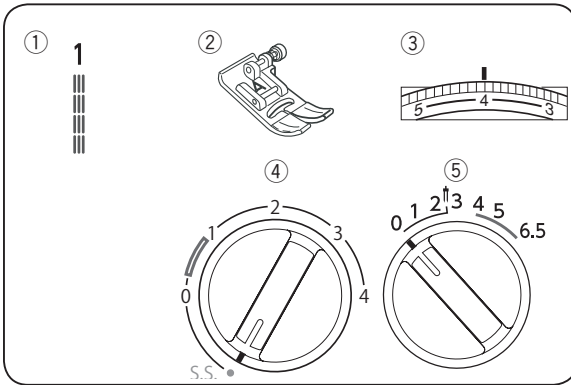

Triple Strength Stitch

- ① Pattern selector: 1
- ② Presser foot: Zigzag foot A
- ③ Thread tension: 2–6
- ④ Stitch length: S.S.
- ⑤ Stitch width: 0

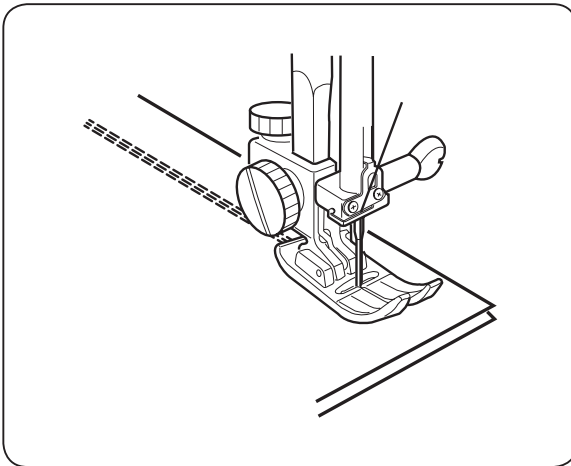

This strong, durable stitch is recommended where both elasticity and strength are needed to insure comfort and durability.

Use it to reinforce areas such as crotch and armhole seams.

Also use when constructing items such as backpacks for extra strength.

The stitch is sewn with two stitches forward and one stitch backward forming a seam that does not rip easily.

Garments should be basted for fitting before seaming.

Sewing Buttons

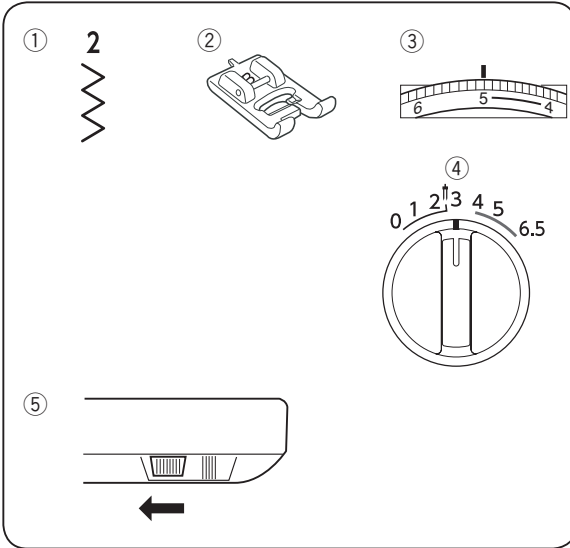

- ① Pattern selector: 2
- ② Presser foot: Transparent buttonhole foot B
- ③ Thread tension: 3–7
- ④ Stitch width: 3–3.5
- ⑤ Feed dog: Lowered

Tape the button over the placement mark. A pin can be placed on top of the foot to form a shank.
 Before lowering the foot, test the needle swing making sure the needle drops in each hole. Adjust the stitch width if necessary. Lower the foot.

Align the both holes of button with the needle swing, lower the foot and depress the foot control.

To strengthen the shank, cut the threads leaving a 20 cm (8") tail. Bring the needle thread down through the hole in the button and wind it around the shank. Draw the thread to the wrong side of fabric and knot.

* When button sewing is finished, return the drop feed lever.

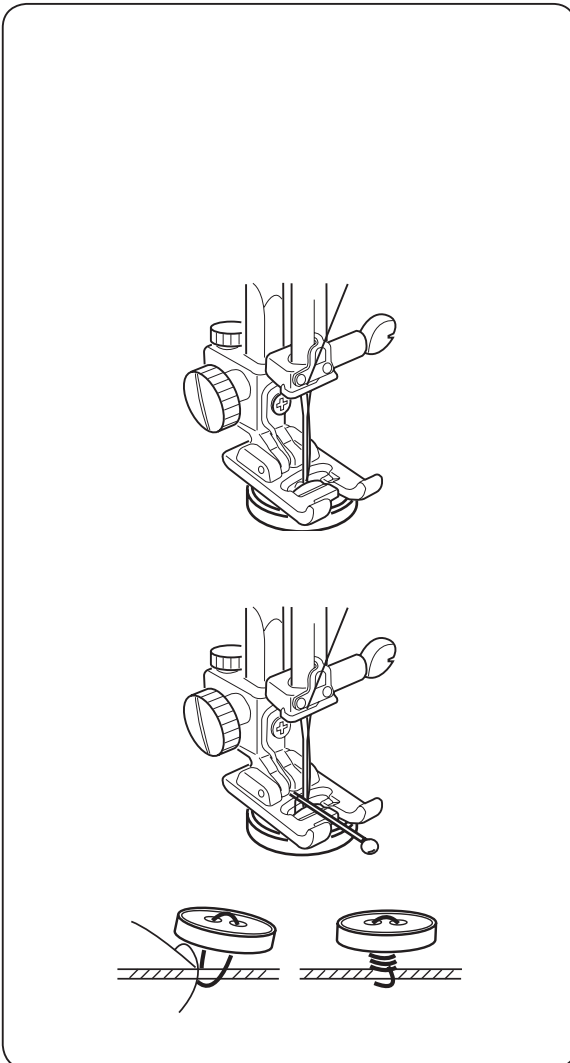

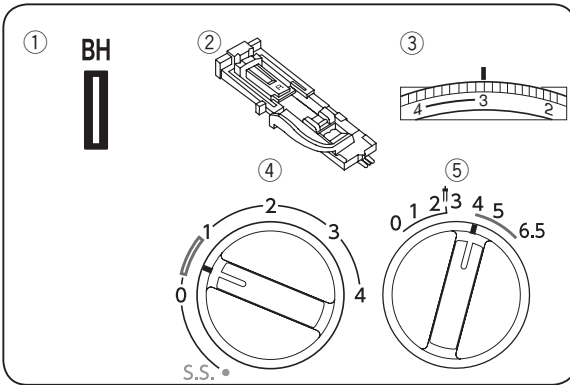

Automatic Buttonhole

- ① Pattern selector: BH
- ② Presser foot: Automatic buttonhole foot R
- ③ Thread tension: 1–5
- ④ Stitch length: 0.5–1
- ⑤ Stitch width: 4–6.5

* The size of buttonhole is automatically set by placing the button in the automatic buttonhole foot R.

* The button holder of the foot takes a button size up to 2.5 cm (1") in diameter.

* Make a test buttonhole on a sample duplicating the fabric, interfacing and seams of the actual garment.

* Place the button on the fabric sample and mark the top and bottom to determine the position of buttonhole.

* Use the interfacing on the stretch fabrics.

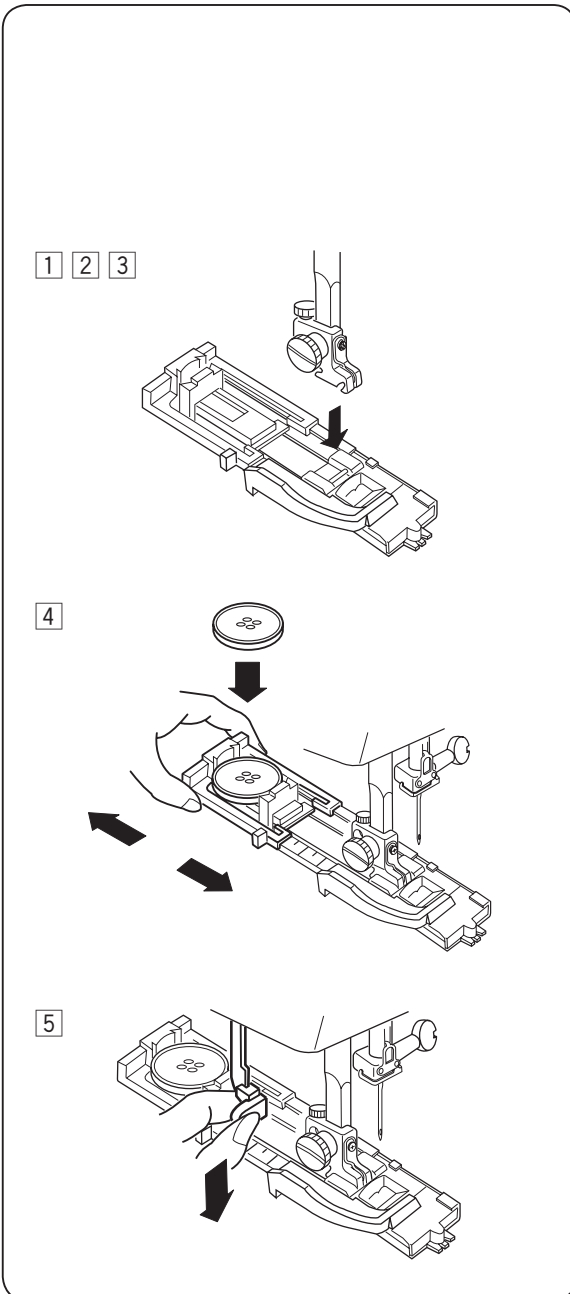

① Turn the handwheel toward you to raise the needle to its highest position. Raise the presser foot lifter.

② Set the pattern indicator at "BH" by turning the pattern selector dial.

③ Attach the automatic buttonhole foot R.

④ Pull the button holder to the back, and place the button in it. Push back the button holder toward you as far as it will go.

⑤ Pull the buttonhole lever downward as far as it will go.

6 7 8

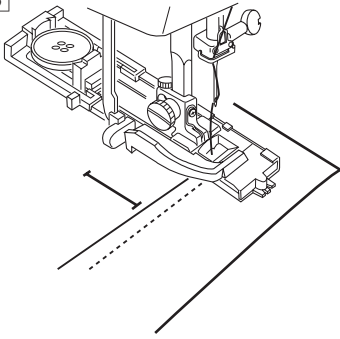

6 Insert the fabric under the foot.
Turn the handwheel one complete turn by your hand.

9

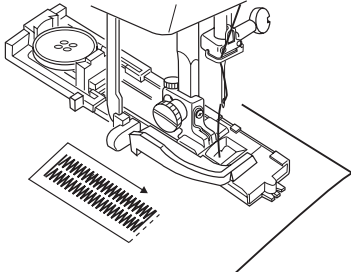

7 Remove the fabric to the left to draw both threads to the left.

8 Insert the garment under the foot, and lower the needle at the starting point.
Then lower the automatic buttonhole foot.

9 Sew slowly and stop the machine at the starting point when a buttonhole is completed.

* The machine sews front bartack and left row first, then the back bartack and right row.

10 11

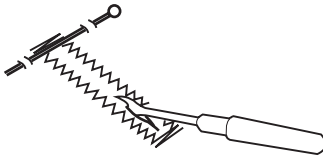

10 Cut the both needle and bobbin threads leaving about 10 cm (4") thread ends.
Draw the needle thread to wrong side of fabric by pulling the bobbin thread.
Then, knot the threads.

11 Cut the both needle and bobbin threads leaving about 10 cm (4") thread ends.
Draw the needle thread to wrong side of fabric by pulling the bobbin thread.
Then, knot the threads.

12 13 BH 1 - - - - - 2 13 BH

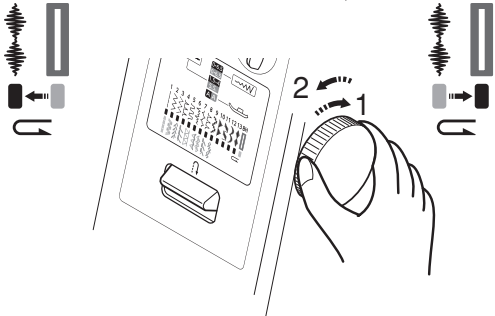

12 To repeat buttonhole sewing.
After a buttonhole is sewn, move the indicator to pattern "13" [↕] by turning the pattern selector dial in the direction of arrow 1, then return the indicator back to "BH" by turning the dial in the direction of arrow 2 to reset for sewing the next buttonhole.

13

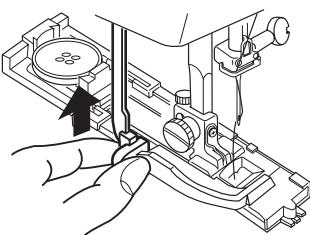

13 When buttonhole sewing is finished, push the buttonhole lever upward as far as it will go.

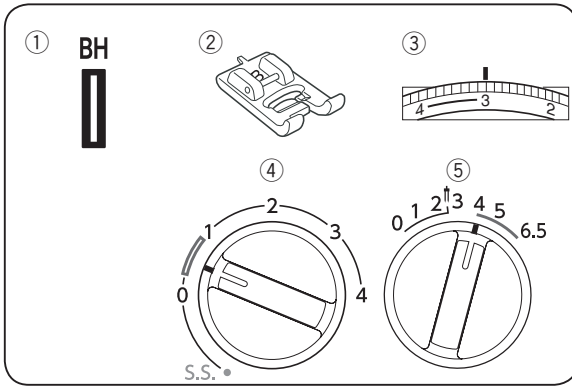

Manual Buttonhole

- ① Pattern selector: BH
- ② Presser foot: Transparent buttonhole foot B
- ③ Thread tension: 1–5
- ④ Stitch length: 0.5–1
- ⑤ Stitch width: 4–6.5

If the diameter of the button is more than 2.5 cm (1"), a buttonhole must be made manually as follows:

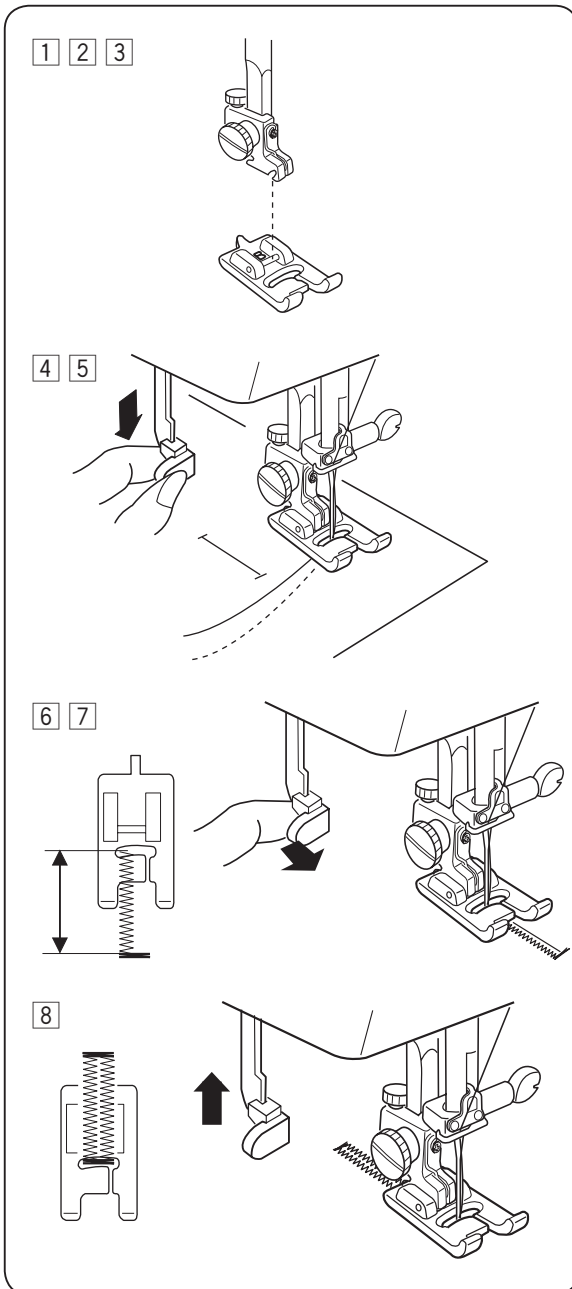

- ① Turn the handwheel toward you to raise the needle to its highest position. Raise the presser foot lifter.
- ② Set the pattern indicator at "BH" by turning the pattern selector dial.
- ③ Attach the transparent buttonhole foot B.
- ④ Pull the buttonhole lever downward as far as it will go.
- ⑤ Lower the needle into the garment where the buttonhole is to start, and lower the foot.
- ⑥ Sew the front bartack and left row, then stop the machine after sewing the desired total length of buttonhole.
- ⑦ Pull the buttonhole lever toward you.
- ⑧ Sew the back bartack and right row, then stop the machine at the starting point. To cut the opening and to reset for sewing the next buttonhole, refer to the instructions on page 24.

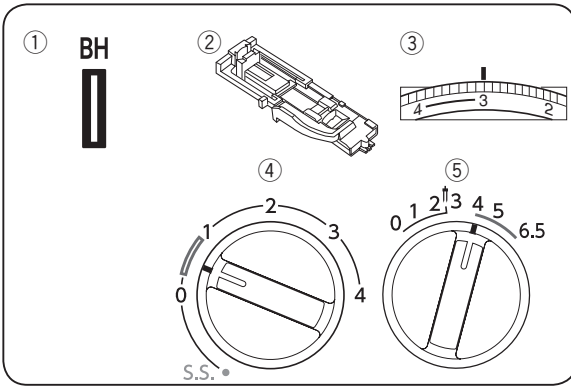

Corded Buttonhole

- ① Pattern selector: BH
- ② Presser foot: Automatic buttonhole foot R
- ③ Thread tension: 1–5
- ④ Stitch length: 0.5–1
- ⑤ Stitch width: 4–6.5

* Set the stitch width in accordance with the thickness of the cord used.

* To cut the opening and to reset for sewing the next buttonhole, refer to the instructions on page 24.

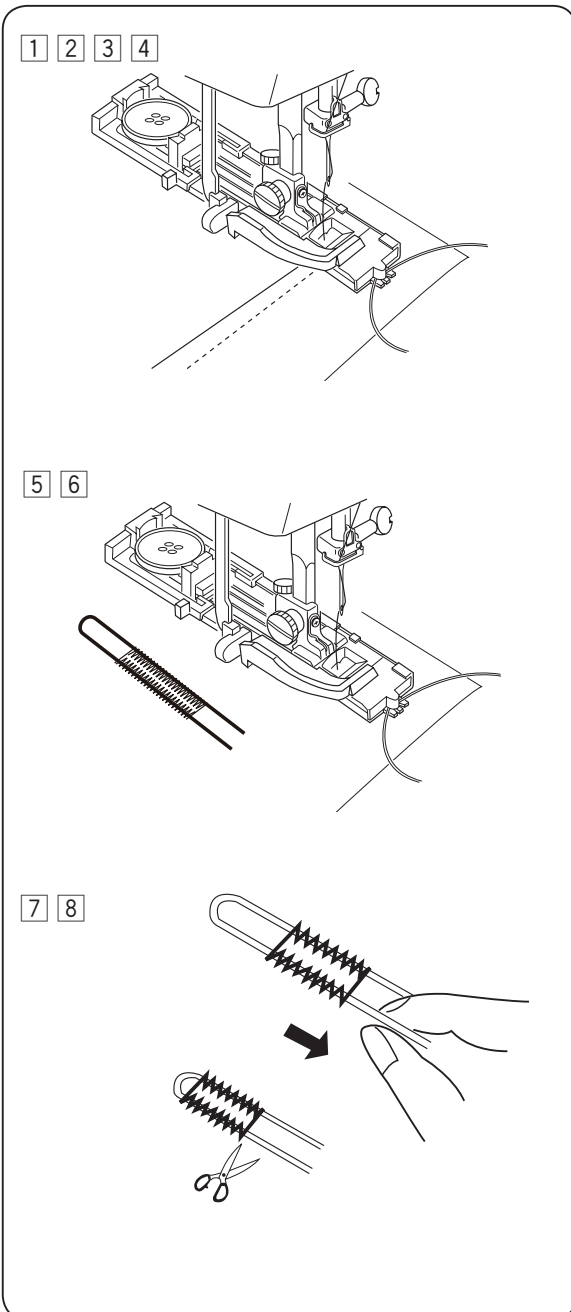

- ① With the buttonhole foot raised, hook the filler cord on the cord spur at the back of the buttonhole foot.
- ② Bring the ends toward you under the buttonhole foot until they clear the front end.
- ③ Hook the filler cord into the forks on the front of the automatic buttonhole foot R to hold them tight.
- ④ Lower the needle into the garment where the buttonhole will start and lower the foot.
- ⑤ Depress the foot control gently and sew the buttonhole. Each side of the buttonhole and the bartacks will be sewn over the cord.
- ⑥ Remove the fabric from the machine and cut the sewing threads.
- ⑦ Pull the left end of the filler cord to tighten it.
- ⑧ Thread the end through a darning needle, draw to the bottom side of the fabric and cut.

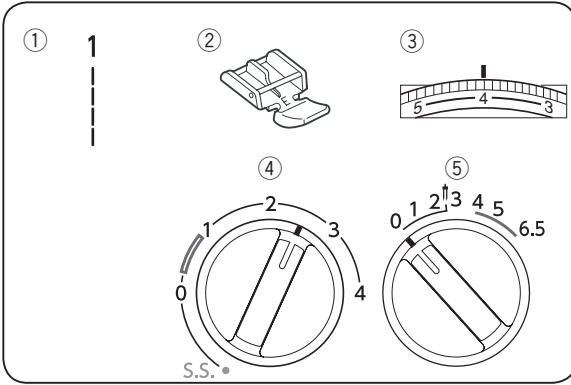

Zipper Application

- ① Pattern selector: 1
- ② Presser foot: Zipper foot E
- ③ Thread tension: 3–6
- ④ Stitch length: 1.5–4
- ⑤ Stitch width: 0

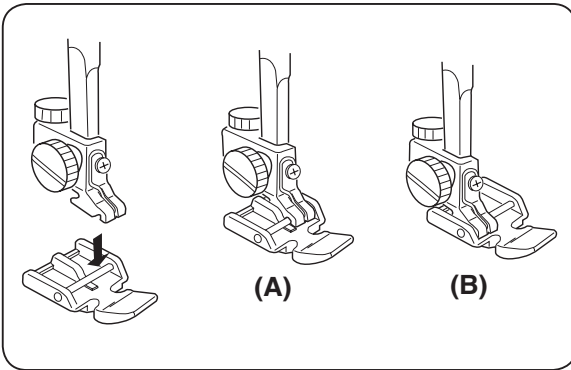

Attaching the zipper foot

- (A) To sew the left side of the zipper, attach the zipper foot to the pin on the right hand side.
- (B) To sew the right side of the zipper, attach the zipper foot to the pin on the left hand side.

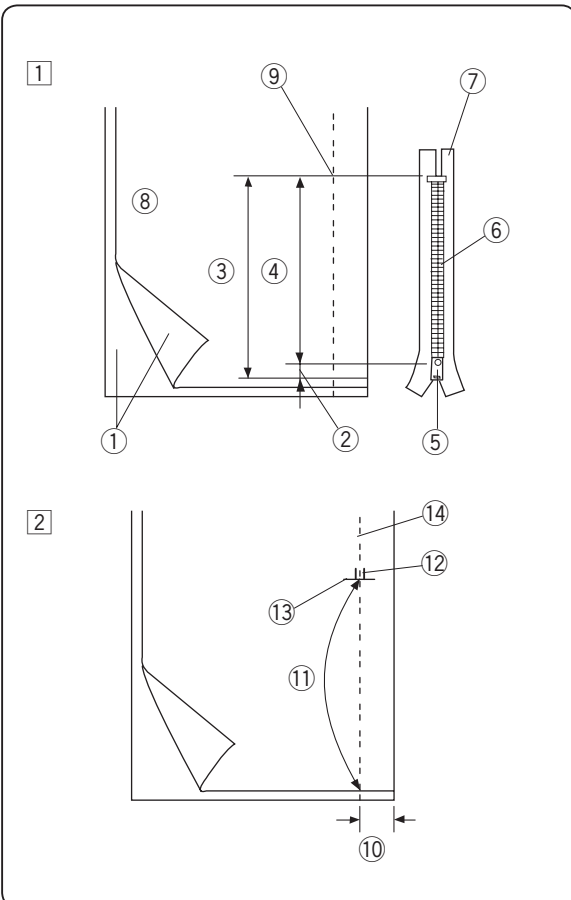

Fabric preparation

- ① Add 1 cm (3/8") to the zipper size. This is the overall opening size.
 - ① Right side of the fabric
 - ② 1 cm (3/8")
 - ③ Opening size
 - ④ Zipper size
 - ⑤ Slider
 - ⑥ Zipper teeth
 - ⑦ Zipper tape
 - ⑧ Wrong side of the fabric
 - ⑨ End of the opening
- ② Place the right (top) sides of the fabric together. Sew a bottom seam 2 cm (5/8") from the right edge to the zipper bottom stop position. Sew a few stitches in reverse to lock. Increase the stitch length to "4", set needle thread tension to "1", and baste the entire length of the fabric.
 - ⑩ 2 cm (5/8")
 - ⑪ Basting
 - ⑫ Reverse stitch
 - ⑬ End of the opening
 - ⑭ Bottom seam

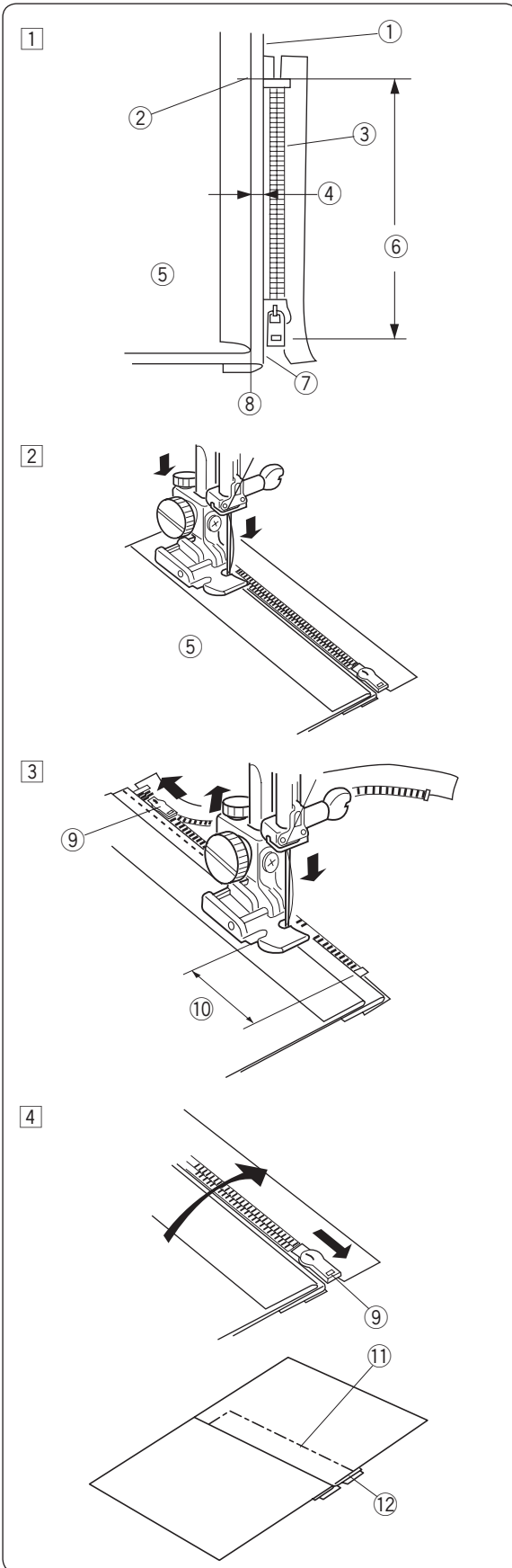

To sew

- 1 Attach zipper foot with the right side pin. Fold back the upper layer seam allowance. Fold back the lower layer seam allowance to leave a 0.4 cm (1/8") margin of fabric.

- ① Lower layer
- ② End of the opening
- ③ Zipper teeth
- ④ 0.4 cm (1/8") margin
- ⑤ Upper layer
- ⑥ Opening size
- ⑦ Folded edge
- ⑧ Basting

- 2 Place zipper teeth next to margin edge and baste the zipper tape to the lower fabric layer. Align zipper foot with margin edge. Return thread tension and stitch length to original settings. Sew a seam the entire length of zipper tape.

- 3 Stop the machine 5 cm (2") before reaching the slider, with needle in the fabric and raise the foot, then unzip a few inches to clear a path for stitching.

- ⑨ Slider
- ⑩ 5 cm (2")

- 4 Remove fabric and close zipper. Take the upper fabric layer and lay it flat over the zipper.

Baste the zipper tape to the upper fabric layer.

- ⑪ Basting
- ⑫ Zipper tape

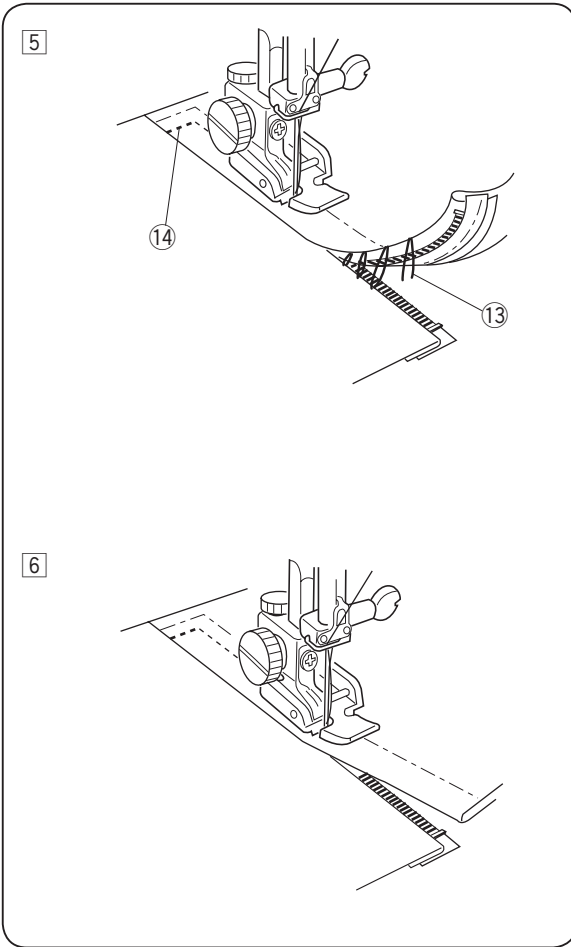

- 5 Raise and release the foot, and re-attach it with the left side pin.
 Starting just below zipper bottom stop, sew across fabric to about 1 cm (3/8") distance from the basting line.
 Turn fabric 90 degrees and sew a seam the entire length of the zipper tape. Before reaching the slider, stop the machine with needle in fabric and raise the foot. Use seam ripper to open a few inches of basting stitch.
- 13 Unstitch basting
 - 14 1 cm (3/8")

- 6 Unzip a few inches to clear a path for stitching.
 At end of seam, sew a few stitches in reverse to lock. Once both sides of zipper are sewn, use the seam ripper to open the basting stitch.

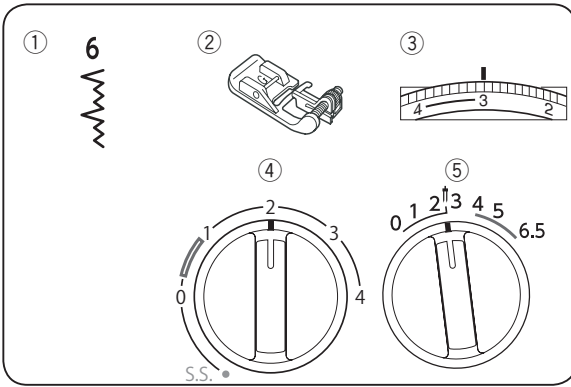

Blind Stitch Hemming

- ① Pattern selector: 6
- ② Presser foot: Blind stitch hem foot G
- ③ Thread tension: 2–4
- ④ Stitch length: 1–3
- ⑤ Stitch width: 2–3

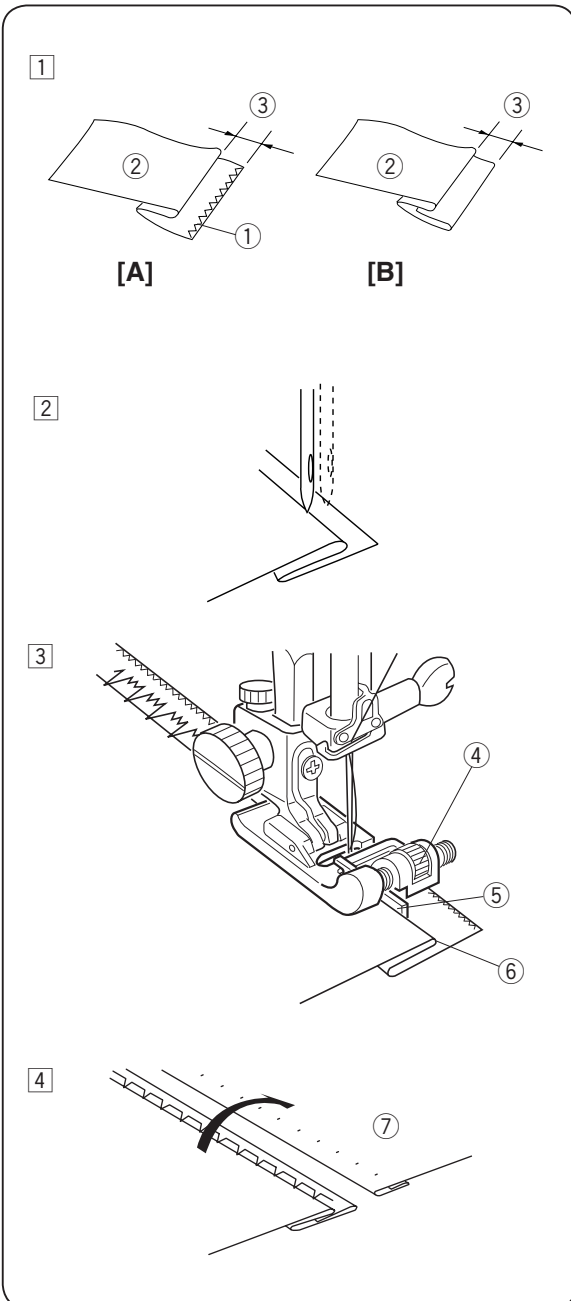

- ① On heavy weight fabrics that ravel, the raw edge should be overcast first.
Fold the hem under the fabric as illustrated for fine or medium fabrics.
Fold a hem with the wrong side up forming a 0.4 – 0.7 cm (3/16"–1/4") allowance.

- A:** Heavy weight fabric
- B:** Fine and medium weight fabric
- ① Overcasting
- ② Wrong side of fabric
- ③ 0.4 – 0.7 cm (3/16"–1/4")

- ② Place the fabric so that the needle just pierces the folded edge when the needle comes over the extreme left side.
Lower the presser foot.
- ③ Turn the screw to align the guide on the foot with the folded edge so that the needle just pierces the fold.
If the needle pierces too far left, move the guide slightly to the left.
If the needle misses the fold, move the guide slightly to the right.
Sew slowly while guiding the folded edge along the guide.
- ④ Open and press the fabric after sewing is finished.

- ④ Screw
- ⑤ Guide
- ⑥ Folded edge

- ⑦ Right side of the fabric

NOTE:

If the needle drops too far left, the stitches will be apparent on the right side of the fabric.

SECTION V DECORATIVE STITCHING

Decorative Satin Stitch Patterns

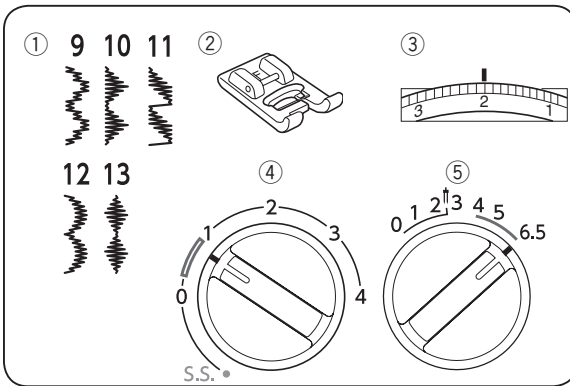

- ① Pattern selector: 9 - 13
- ② Presser foot: Satin stitch foot F
- ③ Thread tension: 1-4
- ④ Stitch length: 0.5-1
- ⑤ Stitch width: 3-6.5

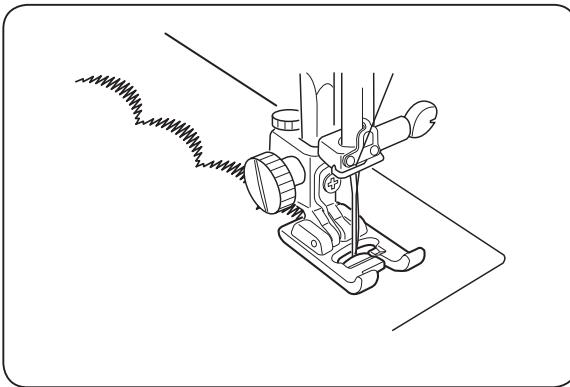

Sew a row of stitches and adjust the thread tension so the needle thread should appear on the reverse side of the fabric.

Test the stitch on the actual fabric for the best results.

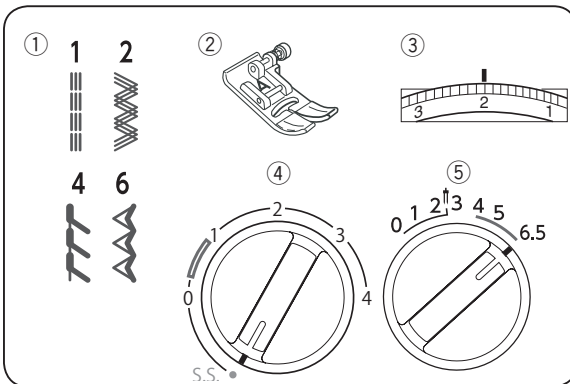

Stretch Stitch Patterns

- ① Pattern selector: 1, 2, 4 or 6
- ② Presser foot: Zigzag foot A
- ③ Thread tension: 1-4
- ④ Stitch length: S.S.
- ⑤ Stitch width: 3-6.5

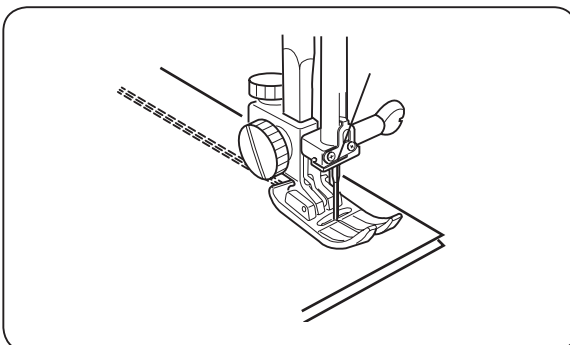

Stitch length of the automatic patterns 1, 2, 4 or 6 are preset, so you do not need to select the stitch length for these patterns.

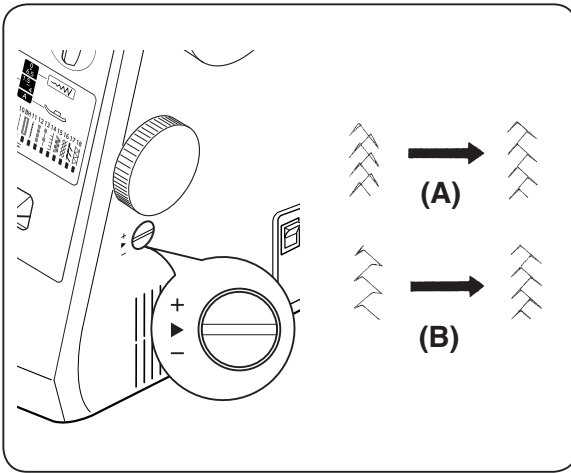

Adjusting Stretch Stitch Balance

If patterns are uneven when sewing with a particular fabric, adjust them with the feed balance dial.

After sewing with an altered dial setting, you must reset the dial to [▶].

(A) When patterns are compressed, correct by turning the dial in the direction of “+”.

(B) When patterns are drawn out, correct by turning the dial in the direction of “-”.

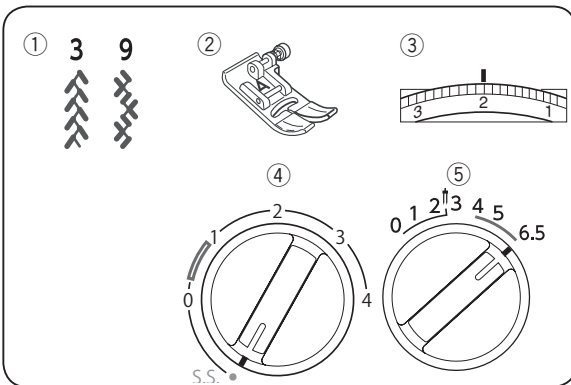

Smocking

- ① Pattern selector: 3 or 9
- ② Presser foot: Zigzag foot A
- ③ Thread tension: 1-4
- ④ Stitch length: S.S.
- ⑤ Stitch width: 3-6.5

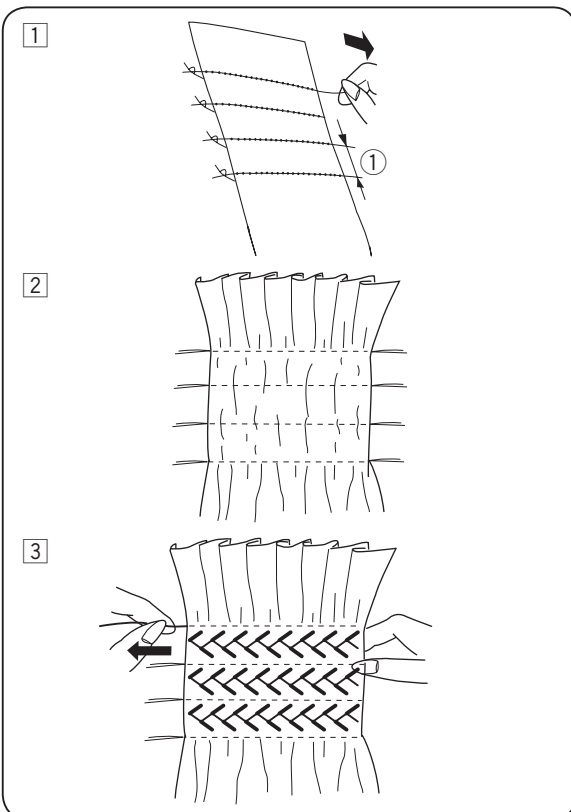

- 1 Choose a soft and lightweight fabric such as batiste, gingham or challis. Cut the fabric three times wider than the project width. Increase the stitch length to “4” and loosen thread tension to “1”. Sew rows of straight stitches 1 cm (3/8”) apart across the area to be smocked.

① 1 cm (3/8”)

- 2 Knot the threads along one end. From the other end, pull the bobbin threads to distribute gathers evenly and secure the threads. Return the thread tension to the original setting.

- 3 Sew rows of the smocking stitch between the gathering stitches. Remove the gathering stitches after finished.

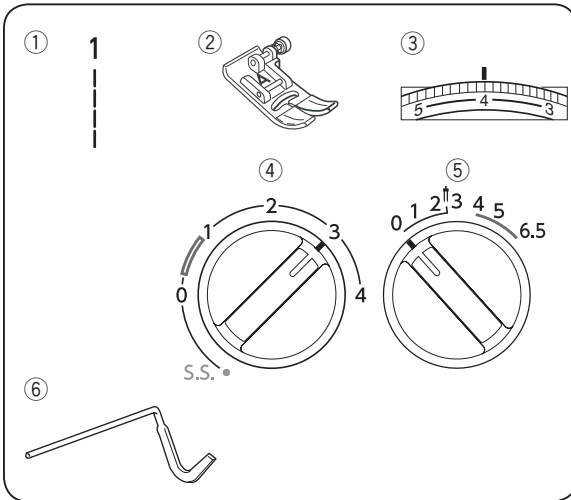

Quilting

- ① Pattern selector: 1
- ② Presser foot: Zigzag foot A
- ③ Thread tension: 3–6
- ④ Stitch length: 1.5–4
- ⑤ Stitch width: 0
- ⑥ Quilting guide bar

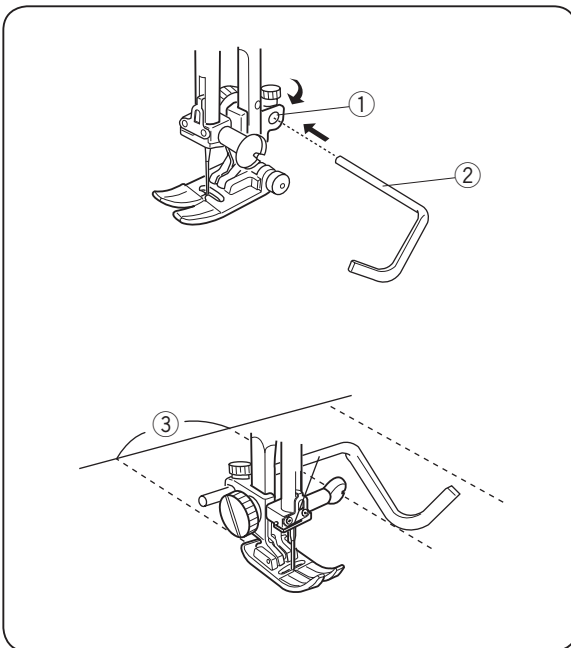

Attaching the quilting guide bar

The quilting guide bar is helpful when sewing parallel, evenly spaced rows of stitching.

Insert the quilting guide bar into the opening and slide the quilting guide bar to the position according to the desired space between seams.

- ① Opening on the foot holder
- ② Quilting guide bar
- ③ Space between seams

Sewing

Sew while tracing the previous seam with the quilting guide bar.

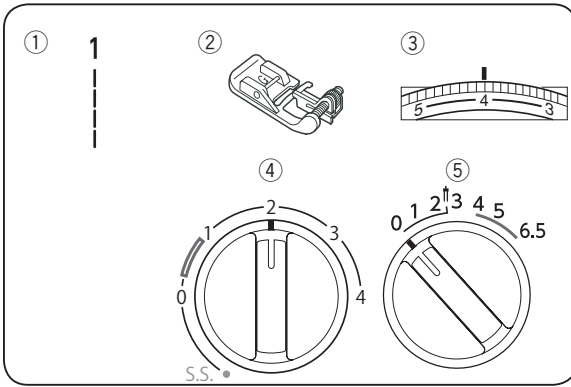

Pin Tucking

- | | |
|---------------------|-------------------------|
| ① Pattern selector: | 1 |
| ② Presser foot: | Blind stitch hem foot G |
| ③ Thread tension: | 2–6 |
| ④ Stitch length: | 1.5–3 |
| ⑤ Stitch width: | 0 |

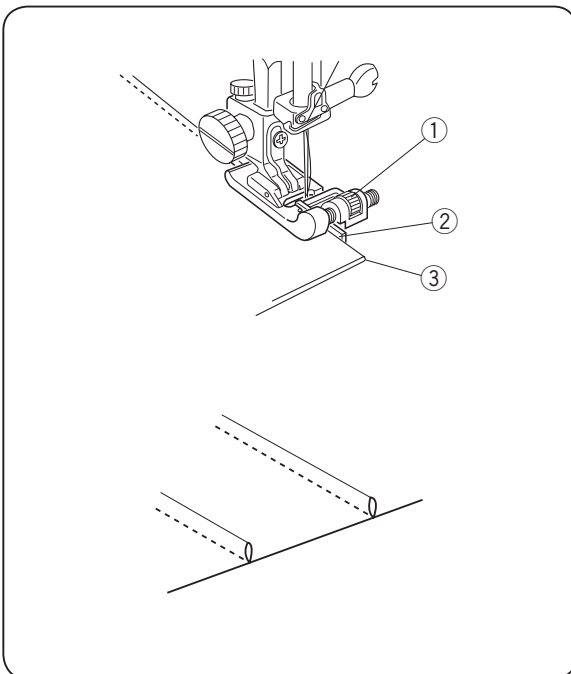

Fold a fabric wrong side together and Lower the needle into the fabric 0.1 – 0.2 cm (1/16") inside the folded edge.

Lower the foot and turn the screw to align the guide on the foot with the folded edge.

Sew slowly while guiding the folded edge along the guide.

Open the fabric and iron press the tucks.

- ① Screw
- ② Guide
- ③ Folded edge

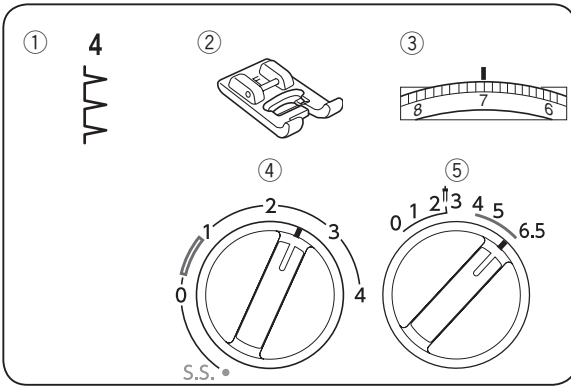

Shell Tuck

- ① Pattern selector: 4
- ② Presser foot: Satin stitch foot F
- ③ Thread tension: 6–8
- ④ Stitch length: 2–3
- ⑤ Stitch width: 5–6.5

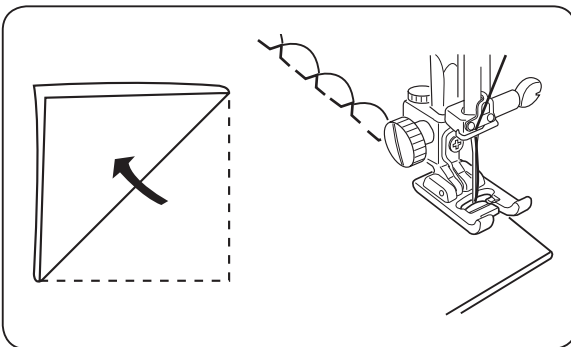

Use a lightweight fabric (tricot, for example). Fold and stitch on the bias. When the needle swings to the right, allow the needle to just clear the folded edge of the fabric. After stitching, open the fabric and iron press the tucks flat to one side.

NOTE:

Increase the needle thread tension to form prominent tucks.

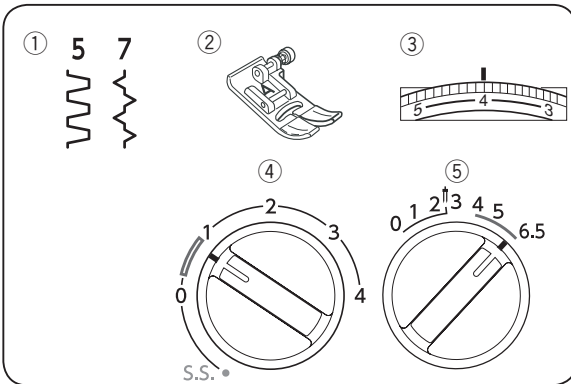

Fagoting

- ① Pattern selector: 5 or 7
- ② Presser foot: Zigzag foot A
- ③ Thread tension: 3–6
- ④ Stitch length: 0.5–1
- ⑤ Stitch width: 5–6.5

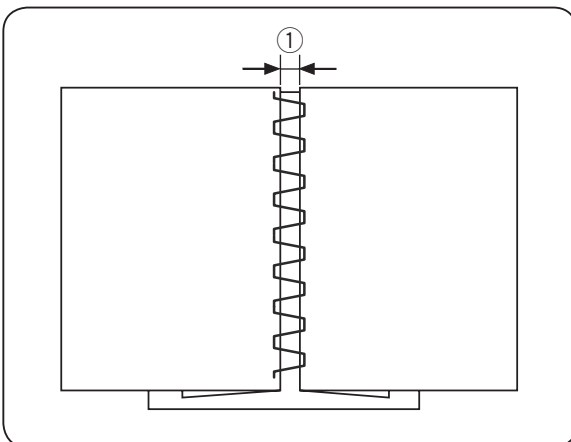

Use this stitch to join two pieces of fabric to create an open work appearance and add design interest.

Fold under each fabric edge 1.5 cm (5/8") and press.

Pin the two edges to a piece of paper or tear away backing 0.3 cm (1/8") apart.

- ① 0.3 cm (1/8")

Sew slowly, guiding the fabric so the needle catches the folded edge on each side.

After finishing sewing, tear away the paper.

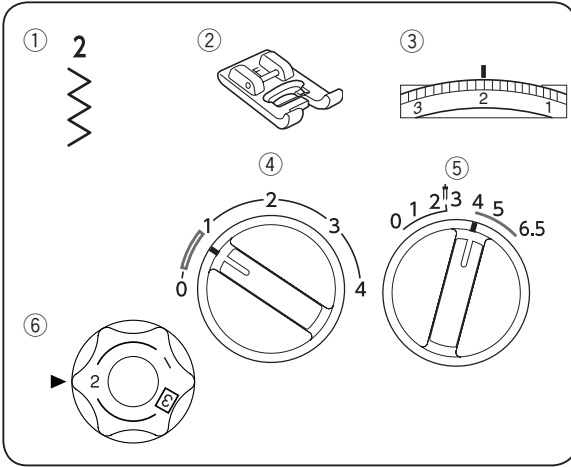

Applique

- ① Pattern selector: 2
- ② Presser foot: Satin stitch F
- ③ Thread tension: 1-4
- ④ Stitch length: 0.5-1
- ⑤ Stitch width: 3-5
- ⑥ Foot pressure: 1 - 2

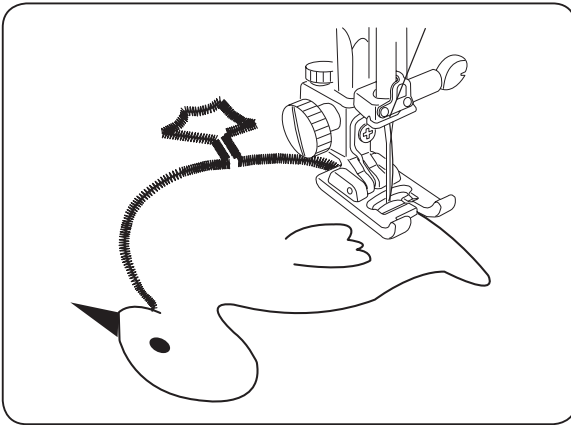

Baste (or fuse with iron-on fabric joiner) applique pieces on the fabric.
 Stitch around the applique making sure the needle falls along the outer edge of the applique.
 When sewing corners, lower the needle down into the fabric.
 Raise the presser foot and pivot the fabric to the right or left.

*When applique sewing is finished, return the pressure dial to 3.

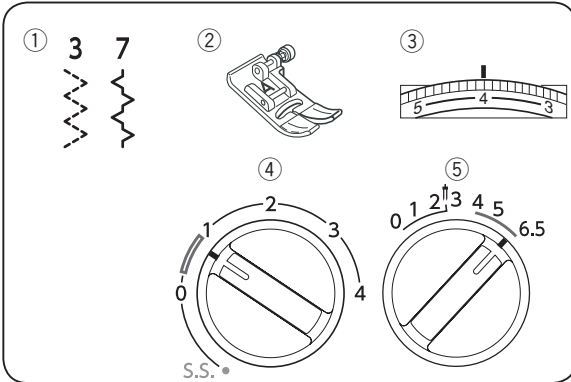

Patchwork

- ① Pattern selector: 3 or 7
- ② Presser foot: Zigzag foot A
- ③ Thread tension: 3-6
- ④ Stitch length: 0.5-1
- ⑤ Stitch width: 5-6.5

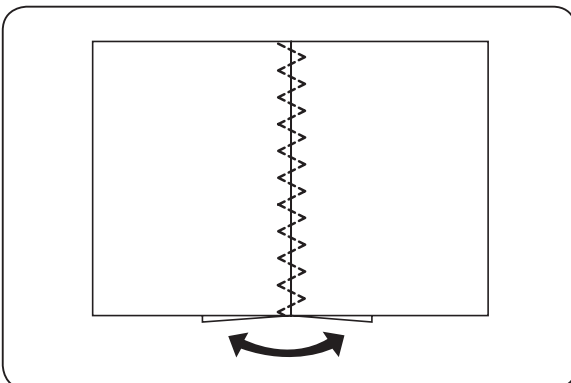

Sew seam and press seam allowance open.
 Sew pattern stitch on the right side of garment centering stitches over the seam line.

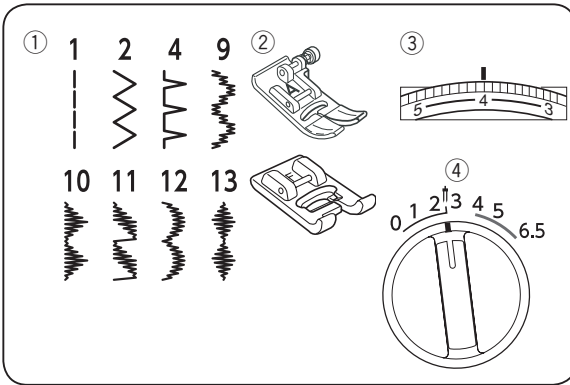

Twin Needle

- ① Pattern selector: 1, 2, 4, 9, 10, 11, 12 or 13
- ② Presser foot: Zigzag foot A (patterns 1 and 2) or Satin stitch foot F (patterns 4, 9, 10, 12 and 13)
- ③ Thread tension: 2–6
- ④ Stitch width: 0–2.5

Adjust the stitch length as indicated on the guide message window (refer to page 16).

Replace the needle with the twin needle supplied with the standard accessories.



CAUTION:

Turn the power switch off before changing the needle.
 Do not use twin needles other than one included in the standard accessories, otherwise the needle may hit the needle plate, foot or hook and break.

Insert the extra spool pin into the hole in the foot storage compartment.

Place a spool of thread on the extra spool pin and fix the spool with the spool holder.

- ① Extra spool pin

Draw both threads from the spools and pass them through the threading points from points ① to ③.

Make sure that the two strands of thread from the spools do not get tangled.

NOTE:

Threading from points ① to ③ is the same as for a single needle (refer to page 12).

- ④ Slip one of the threads through the needle bar thread guide on the left, and the other one on the right.

- ⑤ Thread the needles from front to back.

NOTE:

The needle threader cannot be used with the twin needle.

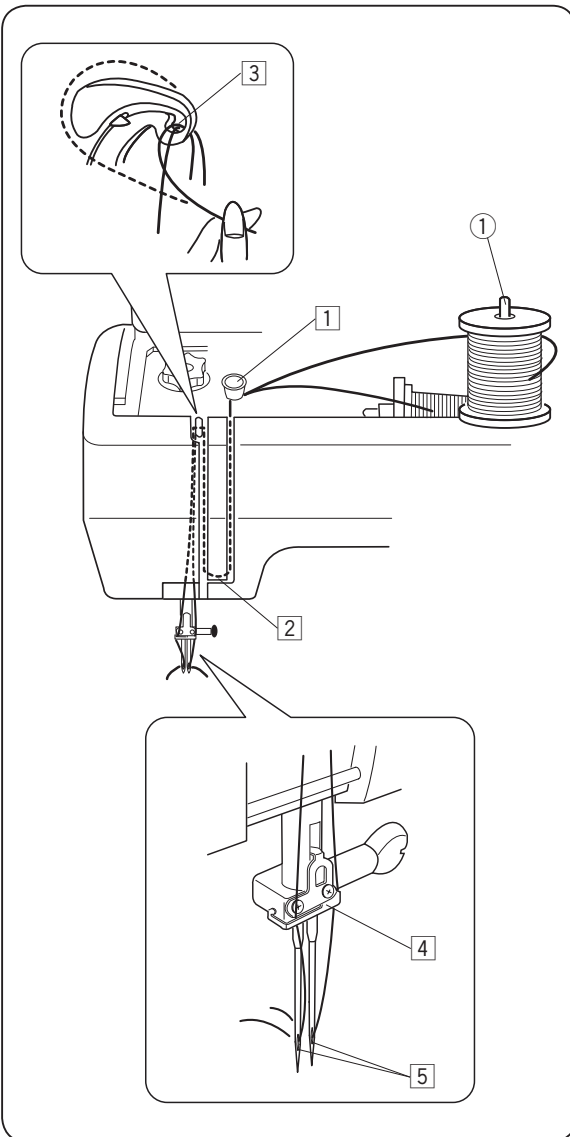

SECTION VI CARE AND MAINTENANCE



WARNING:

Turn the power switch off and unplug the machine before cleaning.

Cleaning the Hook Race

Clean the hook area at least once a month. Turn the power switch off and unplug the machine.

Remove the needle and presser foot.

NOTE:

Do not dismantle the machine in any way other than as explained in this section.

1

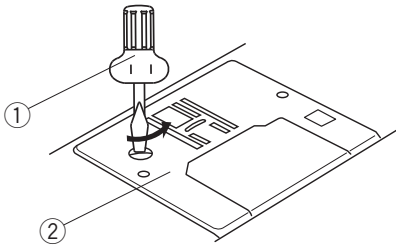

2

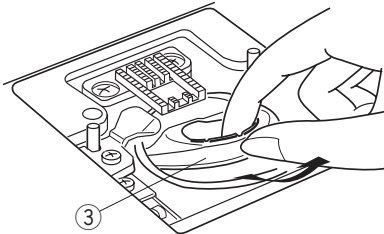

3

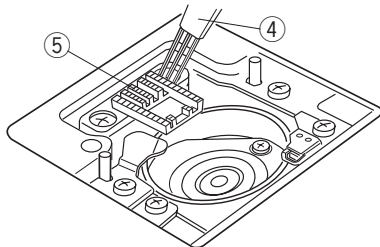
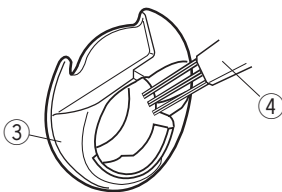

4

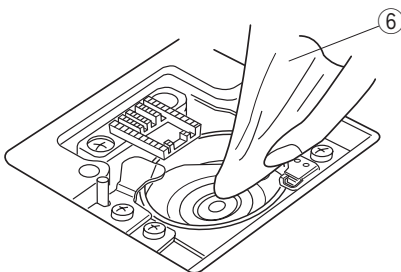

5

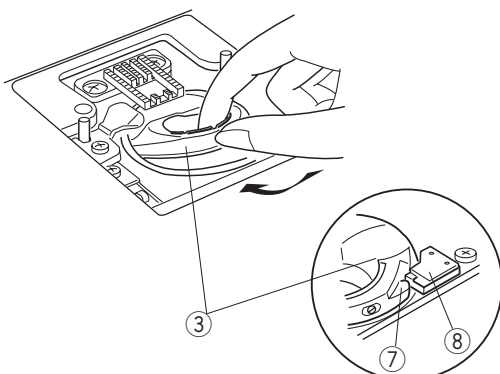

- 1 Remove the screw on the left hand side of the needle plate with the screwdriver. Remove the needle plate.

- 1 Screwdriver
- 2 Needle plate

- 2 Take out the bobbin and bobbin holder.

- 3 Bobbin holder

- 3 Clean the bobbin holder and feed dog with the lint brush.

- 4 Lint brush
- 5 Feed dog

- 4 Clean the hook race with a soft cloth.

- 6 Soft cloth

- 5 Insert the bobbin holder so that the knob fits next to the stopper in the hook race. Insert the bobbin.

Attach the needle plate, presser foot and needle.

- 7 Knob
- 8 Stopper

Trouble Shooting

Condition	Cause	Reference
The machine does not run smoothly and is noisy.	<ol style="list-style-type: none"> 1. Threads have been caught in hook mechanism. 2. The feed dog is packed with lint. 	<p>See Page 38 See Page 38</p>
The needle thread breaks.	<ol style="list-style-type: none"> 1. The needle thread is not threaded properly. 2. The needle thread tension is too tight. 3. The needle is bent or blunt. 4. The needle is incorrectly inserted. 5. The fabric is not being drawn to the rear when sewing is finished. 6. The thread is either too heavy or too fine for the needle. 	<p>See Page 12 See Page 15 See Page 8 See Page 8 See Page 17 See Page 8</p>
The bobbin thread breaks.	<ol style="list-style-type: none"> 1. The bobbin thread is not threaded properly in the bobbin holder. 2. Lint has collected in the bobbin holder. 3. The bobbin is damaged and does not turn smoothly. 	<p>See Page 11 See Page 38 Exchange bobbin.</p>
The needle breaks.	<ol style="list-style-type: none"> 1. The needle is incorrectly inserted. 2. The needle is bent or blunt. 3. The needle clamp screw is loose. 4. The tension of the needle thread is too tight. 5. The fabric is not drawn to the rear when sewing is finished. 6. The needle is too fine for the fabric being sewn. 7. The pattern selector dial has been turned while the needle was in the material. 	<p>See Page 8 See Page 8 See Page 8 See Page 15 See Page 17 See Page 8 See Page 16</p>
Skipped stitches.	<ol style="list-style-type: none"> 1. The needle is incorrectly inserted. 2. The needle is bent or blunt. 3. The needle and/or threads are not suitable for the work being sewn. 4. A BLUE TIPPED needle is not being used for sewing stretch, very fine fabrics and synthetics. 5. The needle thread is not threaded properly. 6. The presser foot pressure is not strong enough. 	<p>See Page 8 See Page 8 See Page 8 See Page 8 See Page 12 See Page 5</p>

Condition	Cause	Reference
Seam Puckering.	<ol style="list-style-type: none"> 1. The needle thread tension is too tight. 2. The needle thread is not threaded correctly. 3. The needle is too heavy for the cloth being sewn. 4. The stitches are too coarse for the fabric being sewn. 5. The presser foot pressure is not correctly adjusted. <p>* When sewing extremely light weight materials, place a sheet of paper underneath the fabric.</p>	<p>See Page 15 See Page 12 See Page 8</p> <p>Make the stitches denser. See Page 5</p>
Stitches form loops below the work.	<ol style="list-style-type: none"> 1. The needle thread tension is too loose. 2. The needle is either too heavy or too fine for the thread. 	<p>See Page 15 See Page 8</p>
The cloth is not feeding smoothly.	<ol style="list-style-type: none"> 1. The feed dog is packed with lint. 2. The presser foot pressure is too weak. 3. The stitches are too fine. 4. The feed dog is not raised after "Drop feed" has been used. 	<p>See Page 38 See Page 5 Make the stitches coarser. See Page 5</p>
The machine does not work.	<ol style="list-style-type: none"> 1. The machine is not plugged in. 2. A thread is caught in the hook race. 3. Bobbin winder spindle is in the winding position. 	<p>See Page 4 See Page 38 See Page 10</p>
The buttonhole stitches are not balanced.	<ol style="list-style-type: none"> 1. The stitch length is not suitable for the fabric being sewn. 2. The work is being pulled or held back. 3. Interfacing is not used with stretch fine fabrics. 	<p>See Pages 23, 25 and 26 Do not force the fabric for guiding. See Page 23</p>

