

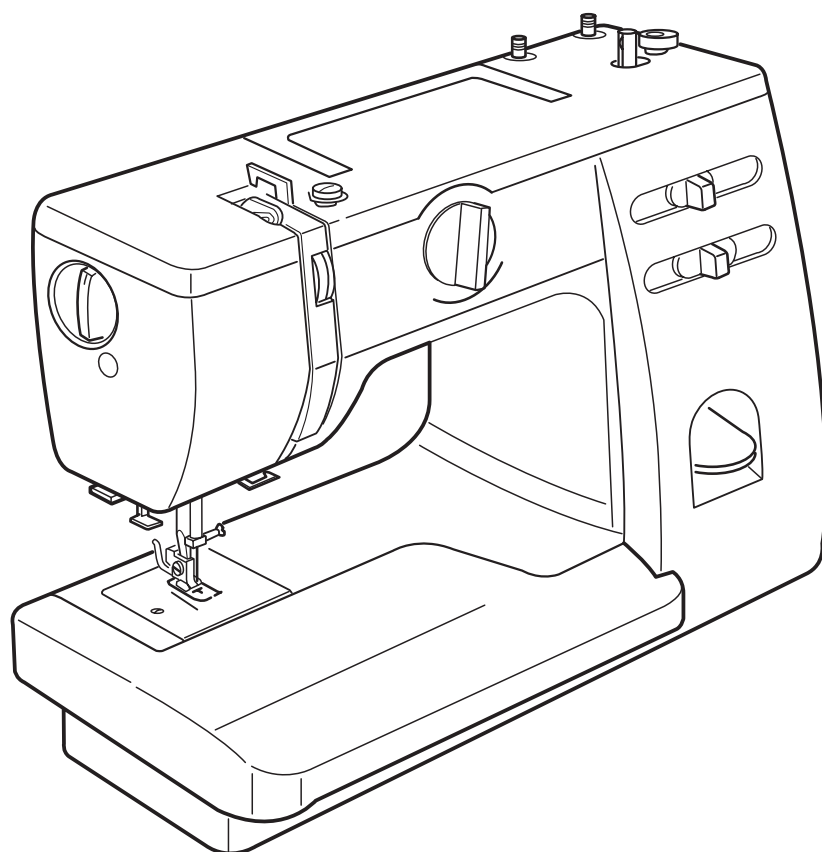

View this machine and more at:

<https://www.thesewingstudio.co.uk>

# ***INSTRUCTION BOOK***



**Models 419S & 423S**

# IMPORTANT SAFETY INSTRUCTIONS

When using an electrical appliance, basic safety precautions should always be followed, including the followings:  
Read all instructions before using this appliance.

## **DANGER** —To reduce the risk of electric shock:

1. An appliance should never be left unattended when plugged in. Always unplug this sewing machine from the electric outlet immediately after using and before cleaning.
2. Always unplug before replacing a sewing machine bulb. Replace bulb with same type rated 15 Watts.

## **WARNING** — To reduce the risk of burns, fire, electric shock, or injury to persons:

1. Do not allow to be used as a toy. Close attention is necessary when this sewing machine is used by or near children.
2. Use this appliance only for its intended use as described in this manual.  
Use only attachments recommended by the manufacturer as contained in this manual.
3. Never operate this sewing machine if it has a damaged cord or plug, if it is not working properly, if it has been dropped or damaged, or dropped into water.  
Return this sewing machine to the nearest authorized dealers or service center for examination, repair, electrical or mechanical adjustment.
4. Never operate the appliance with any air opening blocked. Keep ventilation openings of this sewing machine and foot control free from accumulation of lint, dust and loose cloth.
5. Never drop or insert any object into any opening.
6. Do not use outdoors.
7. Do not operate where aerosol (spray) products are being used or where oxygen is being administered.
8. To disconnect, turn all controls to the off ("O") position, then remove plug from outlet.
9. Do not unplug by pulling on cord. To unplug, grasp the plug, not the cord.
10. Keep fingers away from all moving parts. Special care is required around the sewing machine needle.
11. Always use the proper needle plate. The wrong plate can cause the needle to break.
12. Do not use bent needles.
13. Do not pull or push fabric while stitching. It may deflect the needle causing it to break.
14. Switch this sewing machine off ("O") when making any adjustment in the needle area, such as threading the needle, changing the needle, threading the bobbin or changing the presser foot, and the like.
15. Always unplug this sewing machine from the electrical outlet when removing covers, lubricating, or when making any other adjustments mentioned in this manual.

## **SAVE THESE INSTRUCTIONS**

# TABLE OF CONTENTS

## SECTION 1. ESSENTIAL PARTS

Name of Parts .....	2
---------------------	---

## SECTION 2. GETTING READY TO SEW

Extension Table .....	3
Standard Accessories .....	3
Accessory Storage Box .....	3
Connecting the Machine to the Power Supply .....	4
Foot Control .....	4
Presser Foot Lifter .....	5
To Attach and Remove the Presser Foot .....	5
Presser Foot Pressure Adjusting Dial .....	5
Changing Needle .....	6
● To check the needle .....	6
Thread and Needle Chart .....	6
Setting Spool Pins .....	7
Removing or Inserting the Bobbin Case .....	7
Winding the Bobbin .....	8
Threading Bobbin Case .....	8
Threading the Machine .....	9
Needle Threader .....	10
Drawing Up Bobbin Thread .....	10
Balancing Needle Thread Tension .....	11
Pattern Selector Dial .....	12
Stitch Length Control .....	12
Stitch Width Control .....	12
Reverse Stitch Button .....	13
Dropping the Feed Dog .....	13

## SECTION 3. BASIC SEWING

Straight Stitch Sewing .....	14
To Change Sewing Direction .....	14
Seam Guides Line .....	15
Variable Needle Position .....	15
Zigzag Stitching .....	16

## SECTION 4. UTILITY STITCHING

Overcasting .....	16
Tricot Stitch .....	17
Knit Stitch .....	17
Straight Stretch Stitch .....	18
Sewing on Buttons .....	19
Buttonhole .....	20–21
● To adjust buttonhole stitch density .....	21
Corded Buttonhole .....	22
Zipper Application .....	23
Blind Stitch Hemming .....	24
Rolled Hem .....	25

## SECTION 5. DECORATIVE STITCHING

Shell Tuck .....	26
Stretch Stitch Patterns .....	26
Smocking .....	27
Box Stitching .....	27
Applique .....	28
Decorative Satin Stitch Patterns .....	28

## SECTION 6. CARE OF YOUR MACHINE

Dismantling and Assembling Hook Race Unit .....	29
Cleaning the Feed Dog .....	29
Oiling the Machine .....	30
● Oiling behind the face plate .....	30
● Oiling the shuttle hook area .....	30
Sewing Light .....	30
Troubleshooting .....	31

## SECTION 1. ESSENTIAL PARTS

### Name of Parts

- 1 Reverse stitch button
- 2 Pattern selector dial
- 3 Stitch width control
- 4 Stitch length control
- 5 Bobbin winder stopper
- 6 Bobbin winder spindle
- 7 Spool pins
- 8 Bobbin winder thread guide
- 9 Thread guide
- 10 Thread take-up lever
- 11 Thread tension dial
- 12 Pressure adjusting dial
- 13 Face plate
- 14 Thread cutter
- 15 Needle threader
- 16 Needle plate
- 17 Presser foot holder
- 18 Needle clamp
- 19 Needle
- 20 Presser foot
- 21 Extension table
- 22 Carrying handle
- 23 Handwheel
- 24 Power switch
- 25 Machine socket
- 26 Free arm
- 27 Buttonhole lever
- 28 Presser foot lifter

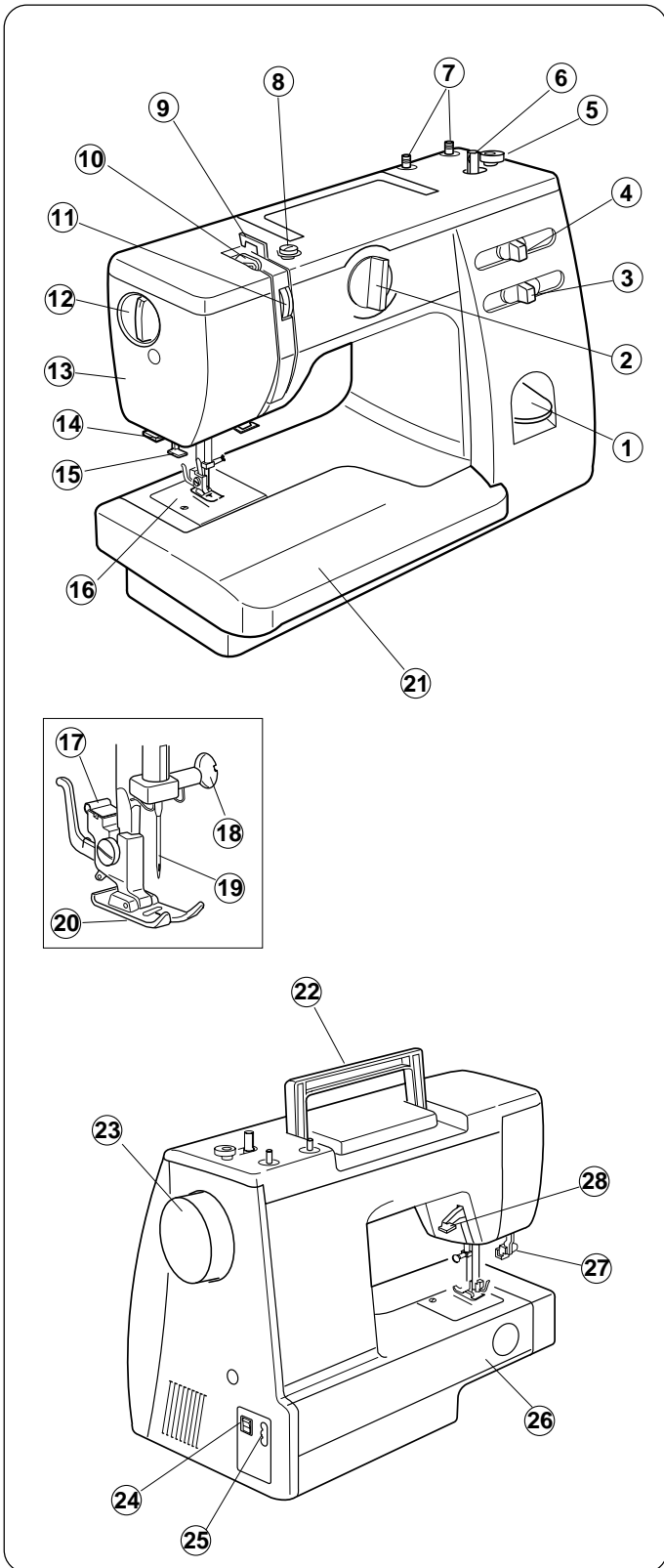

**Note :** The design and specifications are subject to change without prior notice.

## SECTION 2. GETTING READY TO SEW

### Extension Table

The extension table provides added sewing surface and can be easily removed for free arm sewing.

#### Detaching the table:

Pull the table away from the machine.

#### Attaching the table:

Push the extension table until it snaps into the machine.

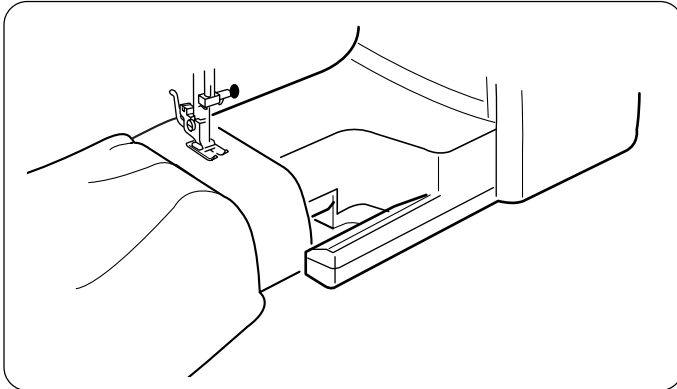
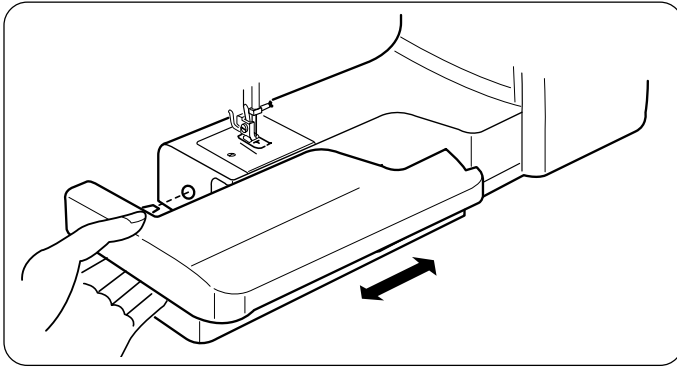

### ● Advantages and uses of free arm sewing:

- À Avoid fabric bunching around the needle when bartacking to reinforce pockets, plackets and waistlines.
- À For stitching sleeves, waistbands, pant legs or any circular garment area
- À For darning socks or mending knees, elbows or areas of wear in children's clothes

### Standard Accessories

- ① Zipper foot
- ② Automatic buttonhole foot
- ③ Hemmer foot
- ④ Bobbins
- ⑤ Set of needles
- ⑥ Seam ripper
- ⑦ screwdriver
- ⑧ Oil
- ⑨ Hem guide

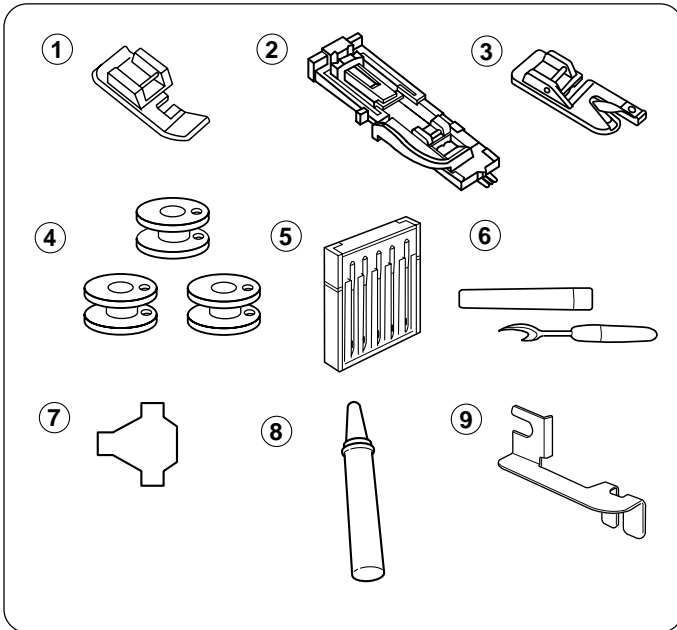

### Accessory Storage Box

Sewing accessories are conveniently located in the extension table.

- ① Accessory storage box

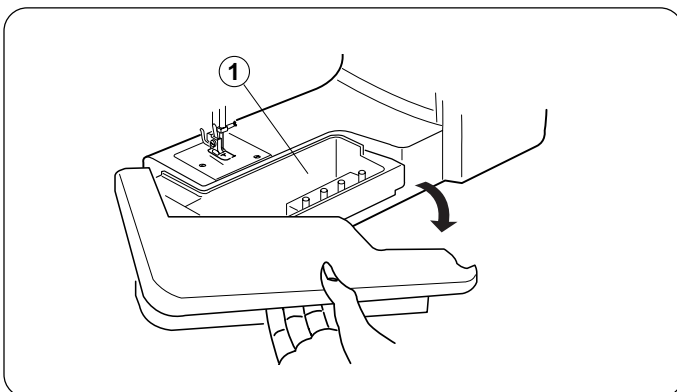

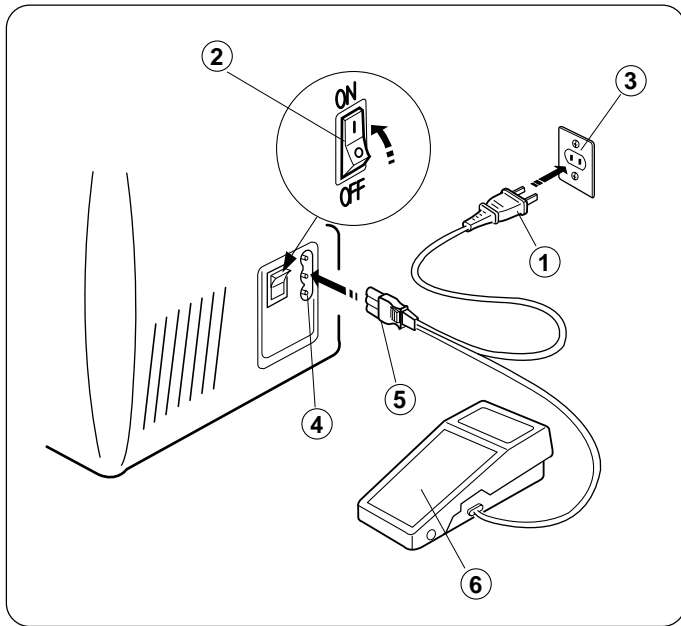

## Connecting the Machine to the Power Supply

Before connecting the power cord, make sure the voltage and frequency shown on the machine conform to your electrical power.

1. Turn off the power switch.
2. Insert the machine plug into the machine socket.
3. Insert the power supply plug into the outlet .
4. Turn on the power switch to turn on the power and sewing light.

- |                     |                  |
|---------------------|------------------|
| ① Power supply plug | ② Power switch   |
| ③ Outlet            | ④ Machine socket |
| ⑤ Machine plug      | ⑥ Foot control   |

## Operating Instruction:

The symbol "0" on a switch indicates the "off" position of a switch.

For appliances with a polarized plug  
(one blade wider than the other):

To reduce the risk of electric shock, this plug is intended to fit in a polarized outlet only one way.

If the plug does not fit fully in the outlet, reverse the plug.

If it still does not fit, contact a qualified electrician to install the proper outlet.

Do not modify the plug in any way.

Foot Control Model YC-482J or TJC-150 is used with Sewing Machine Models 419S and 423S. (For U.S.A. market only)

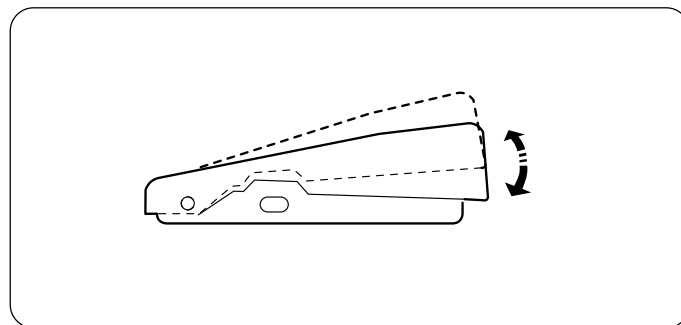
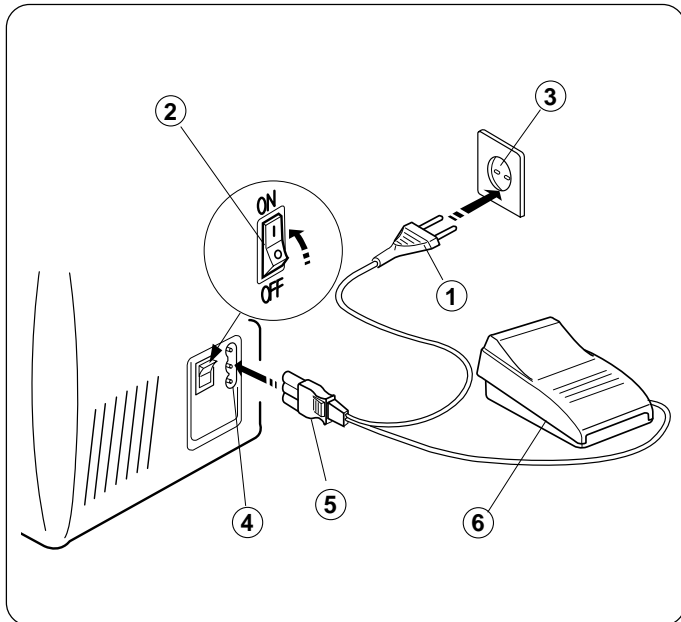

## Foot control

Sewing speed can be varied by the foot control.

The harder you press on the control, the faster the machine runs.

**Caution :** Do not place anything on the foot control, otherwise the machine will start advertently.

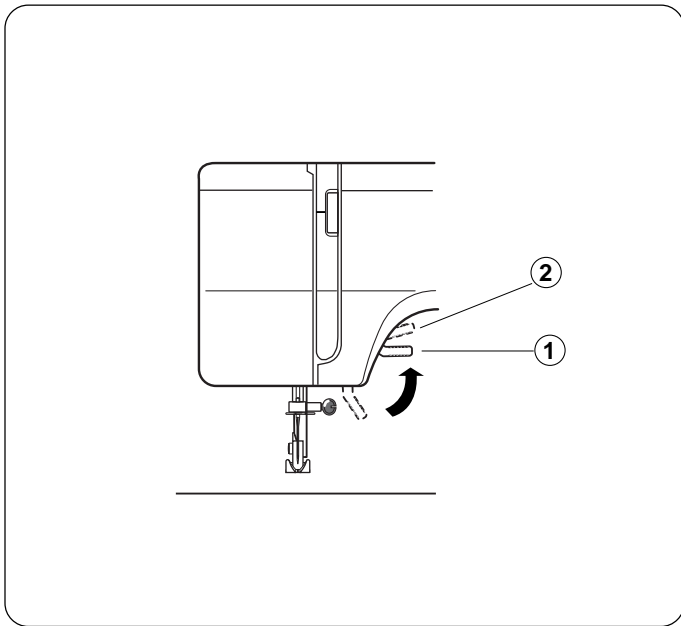

### Presser Foot Lifter

The presser foot lifter raises and lowers your presser foot. You can raise it about 0.6 cm (1/4") higher than the normal up position for easy removal of the presser foot or to help you to place heavy fabric under the foot.

- ① Normal up position
- ② Highest position

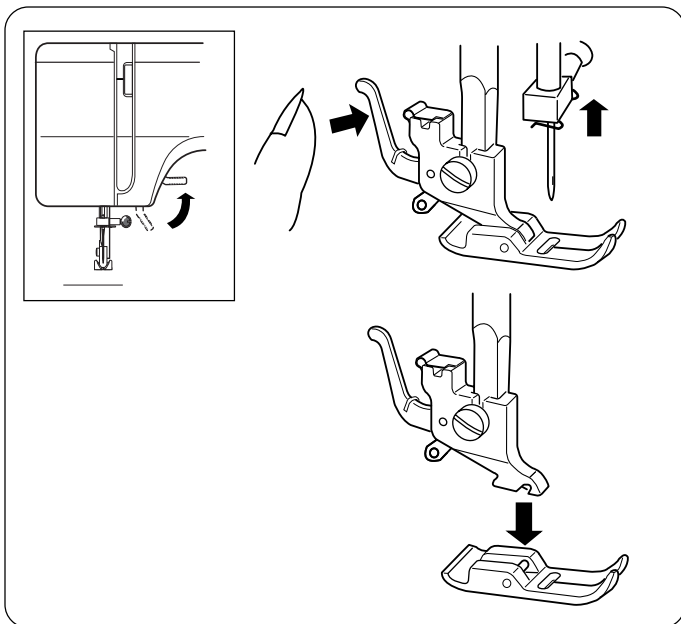

### To Attach and Remove the Presser Foot

#### To remove

Turn the handwheel toward you to raise the needle to its highest position.

Raise the presser foot.

Press the lever on the back of the foot holder.

The presser foot will drop off.

#### To attach

Place the presser foot so the pin on the foot lies just under the groove of the foot holder.

Lower the foot holder to lock the foot in place.

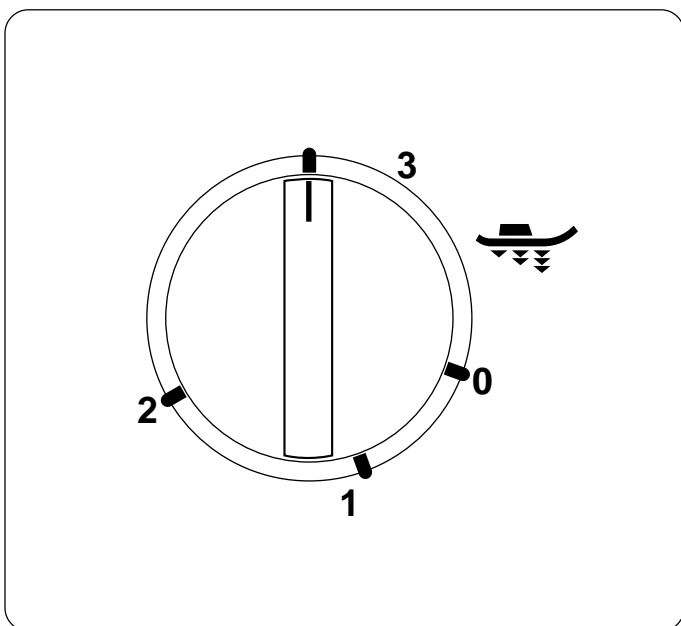

### Presser Foot Pressure Adjusting Dial

The Presser foot pressure adjusting dial should be set at 3 for regular sewing.

Reduce the pressure to 2 for applique, cutwork, drawnwork, basting and embroidery for better maneuverability of fabric.

Velours and knit with a lot of stretch may require a 1 setting.



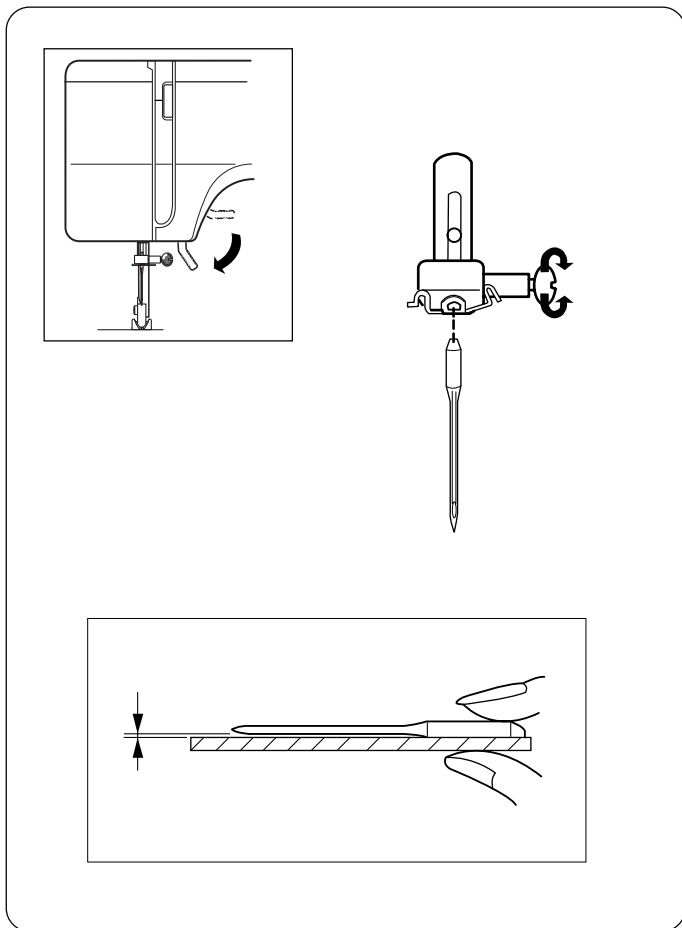

## Changing Needle

Raise the needle by turning the handwheel toward you and lower the presser foot.

Loosen the needle clamp screw by turning it counterclockwise. Remove the needle from the clamp.

Insert a new needle into the clamp with the flat side away from you.

When inserting the needle into the clamp, push it up as far as it will go and tighten the clamp screw firmly with the screwdriver.

- \* Check your needles frequently for barbed or blunted points. Snags and runs in knits, fine silks and silk-like fabrics are permanent and are almost always caused by a damaged needle.

### ● To check the needle

Place the flat side of the needle on something flat (needle plate, glass etc.). The clearance between the needle and flat surface should be consistent. Never use a bent or blunt needle.

	Fabrics	Thread	Needle Size
<b>Light weight</b>	Crepe de Chine, Voile, Lawn, Organdy, Georgette, Tricot	Fine Silk Fine Cotton Fine Synthetic Fine Cotton Covered Polyester	9/65 or 11/75
<b>Medium weight</b>	Linens, Cotton, Pique, Serge, Double Knits, Percale	50 Silk 50 to 80 Cotton 50 to 60 Synthetic Cotton Covered Polyester	11/75 or 14/90
<b>Heavy weight</b>	Denim, Tweed, Gabardine, Coating, Drapery and Upholstery Fabric	50 Silk  40 to 50 Cotton 40 to 50 Synthetic Cotton Covered Polyester	14/90  16/100

## Thread and Needle Chart

- \* In general, fine threads and needles are used for sewing thin fabrics, and thicker threads and needles are used for sewing heavy fabrics. Always test thread and needle size on a small piece of fabric which will be used for actual sewing.
- \* Use the same thread for needle and bobbin.
- \* When sewing stretch, very fine fabrics and synthetics, use a BLUE TIPPED needle. The blue tipped needle effectively prevents skipped stitches.
- \* When sewing very fine fabrics, sew over a piece of paper to prevent seam puckering.

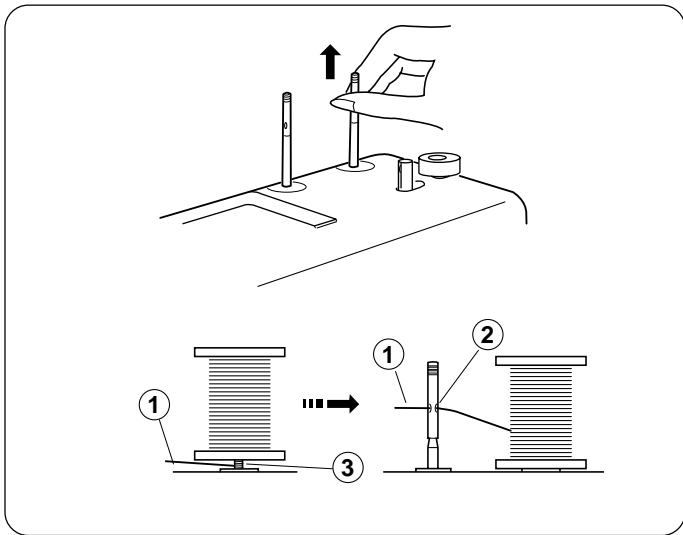

## Setting Spool Pins

The spool pins are used for holding the spool of thread in order to feed thread to the machine.

To use, pull up the spool pin. Push down for storage.

- ① Needle thread
- ② Hole
- ③ Tangle

**Note :** When using thread which has tendency to tangle around spool pin, thread through the hole of spool pin as shown.

The hole should face the thread spool.

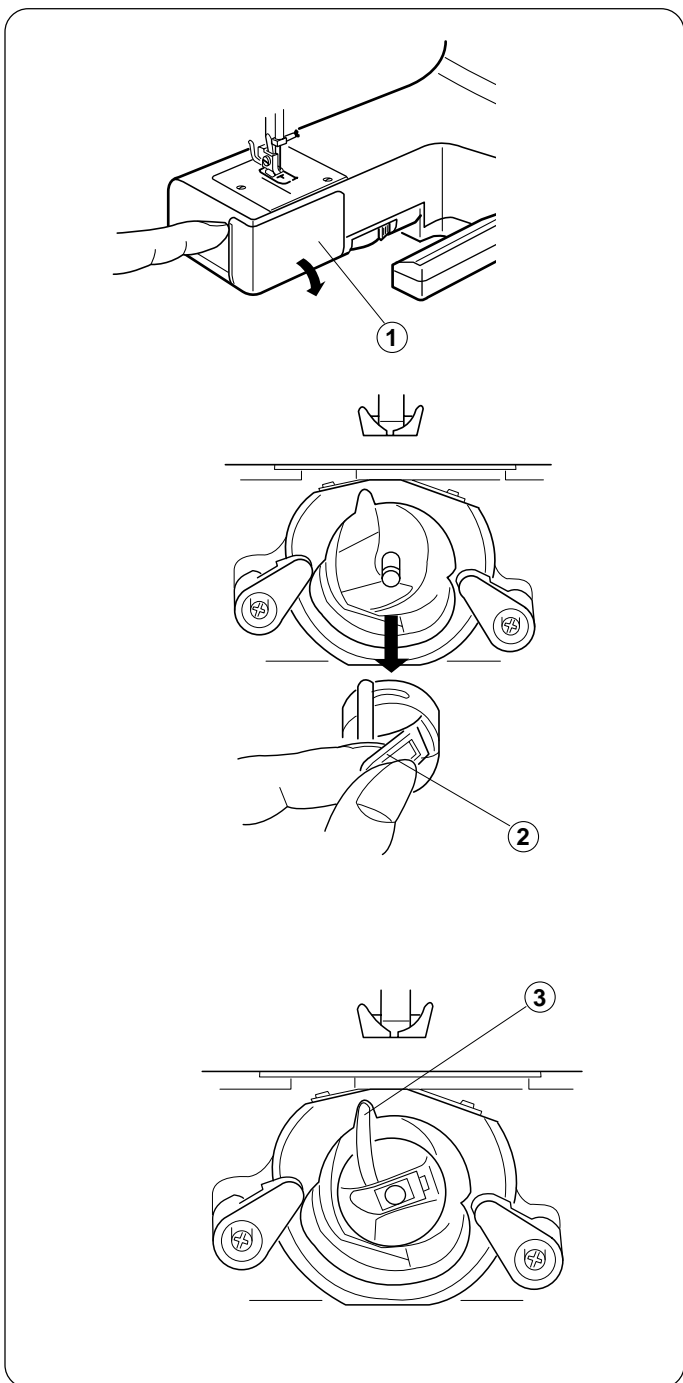

## Removing or Inserting the Bobbin Case

Open the hook cover.

- ① Hook cover

Raise the needle by turning the handwheel toward you.  
Take out the bobbin case by holding the latch.

- ② Latch

When inserting the bobbin case, place the horn into the recess of the hook race.

- ③ Horn

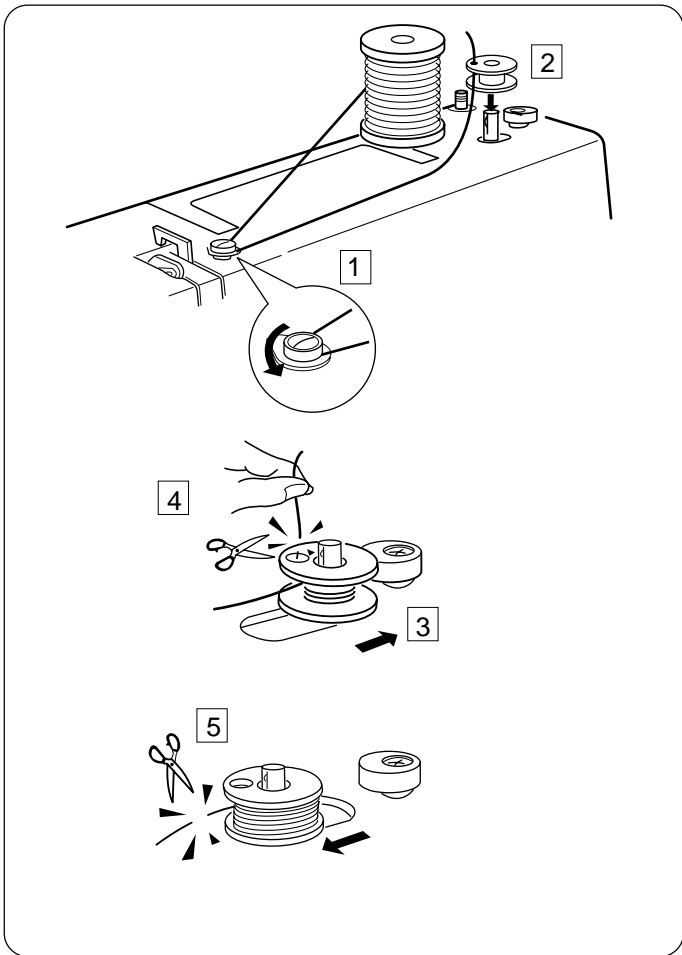

## Winding the Bobbin

- 1 Draw the thread from spool.  
Guide the thread around the bobbin winder thread guide.
- 2 Insert the thread through the hole in the bobbin from the inside to the outside.  
Put the bobbin on the bobbin winder spindle.
- 3 Push it to the right.
- 4 With the free end of the thread held in your hand, depress the foot control.  
Stop the machine when the bobbin has made a few turns, and cut the thread close to the hole on the bobbin.
- 5 Depress the foot control again.  
When the bobbin is fully wound, stop the machine.  
Return the bobbin winder spindle to its original position by moving the spindle to the left, and cut the thread.

**Note :** Return the bobbin winder spindle when the machine stops.

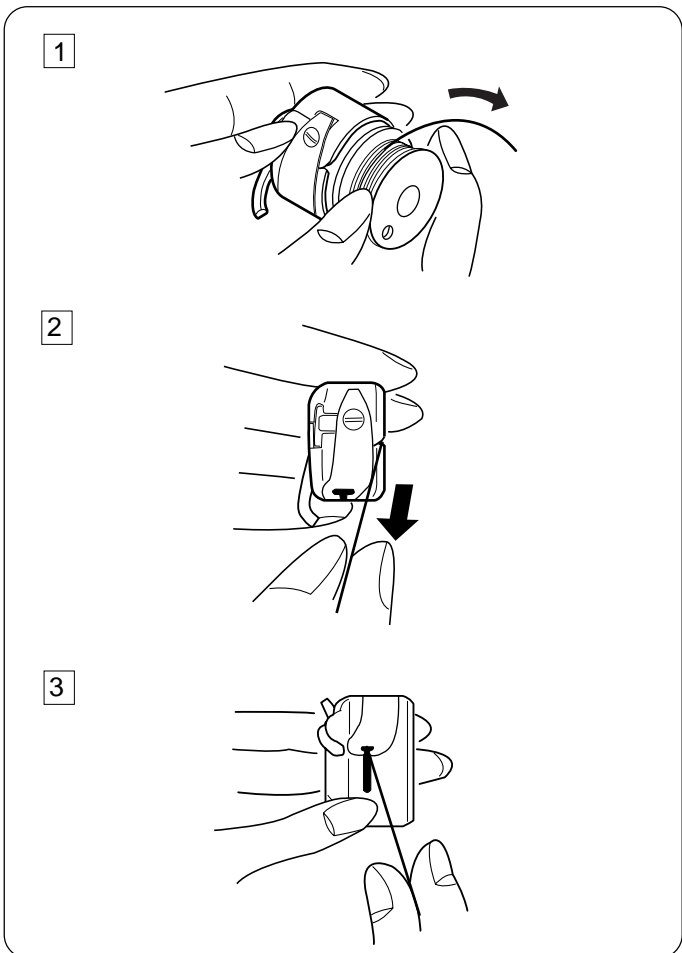

## Threading Bobbin Case

- 1 Place the bobbin into the bobbin case.  
Make sure the thread unwinds in the direction of arrow.
- 2 Pull the thread into the bobbin case slot.
- 3 Draw the thread under the tension spring and into the delivery eye.

\* Leave about 10 cm (4") of free thread.

## Threading the Machine

Raise the take-up lever to its highest position by turning the handwheel toward you.

Raise the presser foot.

Place a spool on the spool pin as shown, with thread coming from back of the spool.

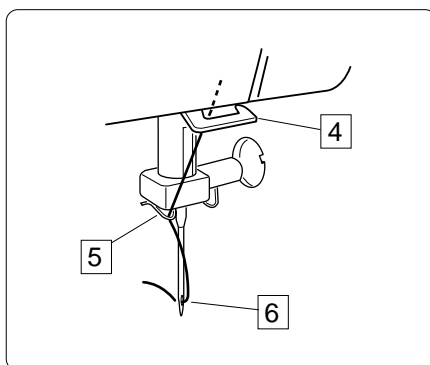
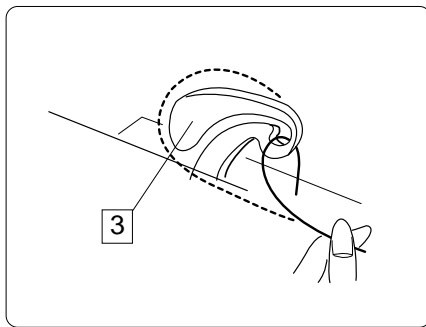
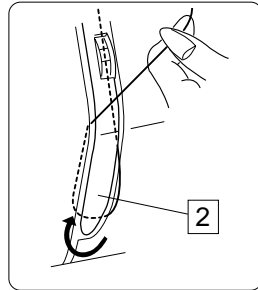
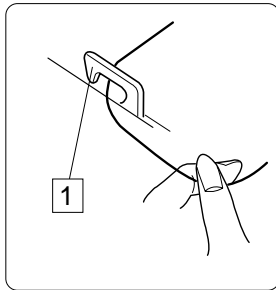
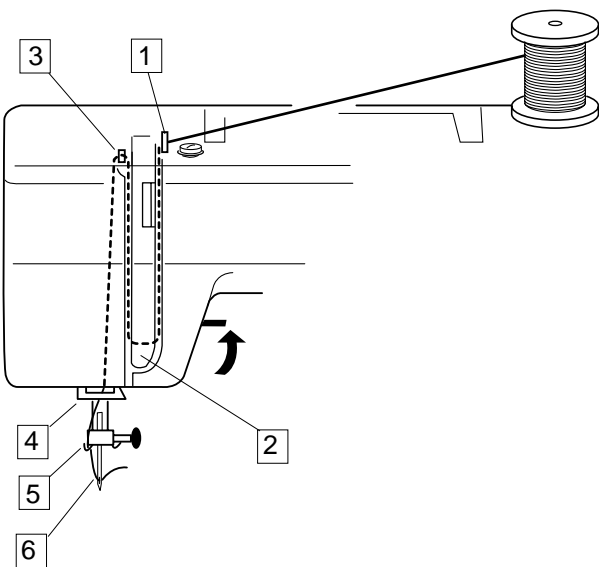

- 1 Draw the thread into thread guide.
- 2 While holding the thread near spool, draw thread down into the tension area and then around the check spring holder.
- 3 Firmly draw the thread up and through the take-up lever from right to left.
- 4 Then draw the thread down and slip it into the lower thread guide.
- 5 Draw the thread down and slip it into needle bar thread guide on the left.
- 6 Thread the needle eye from front to back.

\* Refer to page 10 for the built-in needle threader.

**Note :** You may want to cut the end of thread with sharp scissors for easier needle threading.

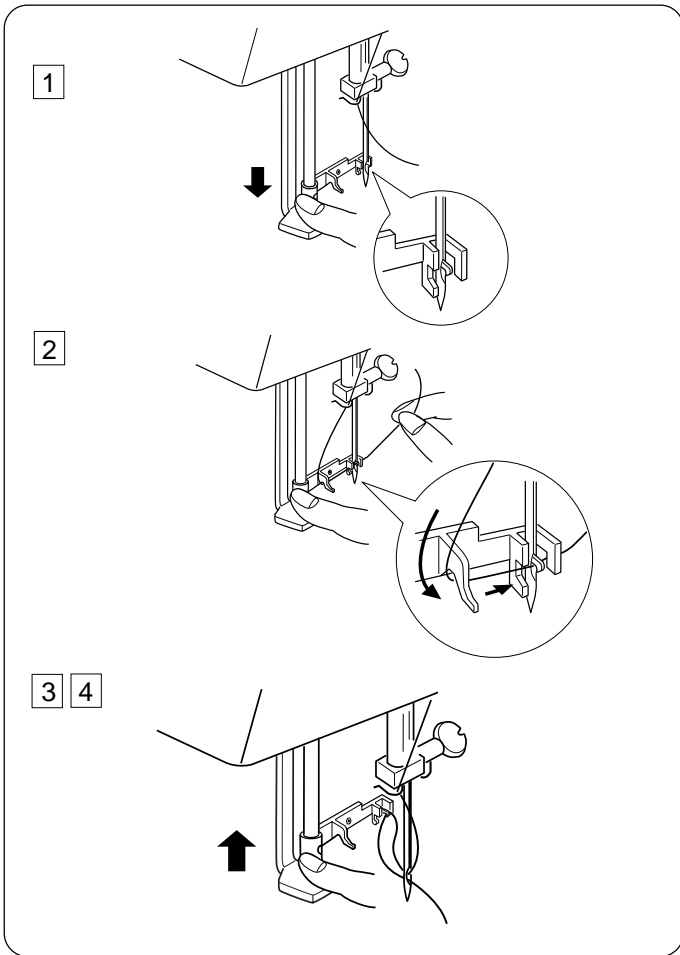

## Needle Threader

- 1 Raise the needle to its highest position.  
Press down the needle threader knob as far as it will go.  
The hook comes out through the needle eye from behind.
- 2 Pull the thread down around the thread guide then pass it from the left and under the hook.
- 3 Release the knob slowly while holding the thread end with your hand.  
A loop of the thread is pulled up through the needle eye.
- 4 Remove the loop from the threader and pull out the thread end from the needle eye.

**Note:** The needle threader can be used with a #11/75 to #16/100 needle or Janome Blue Tipped needle. Thread size 50 to 100 would work well.

**Caution:** Be sure to raise the needle to its highest position when using the needle threader, otherwise the hook will miss the needle eye and will be damaged.

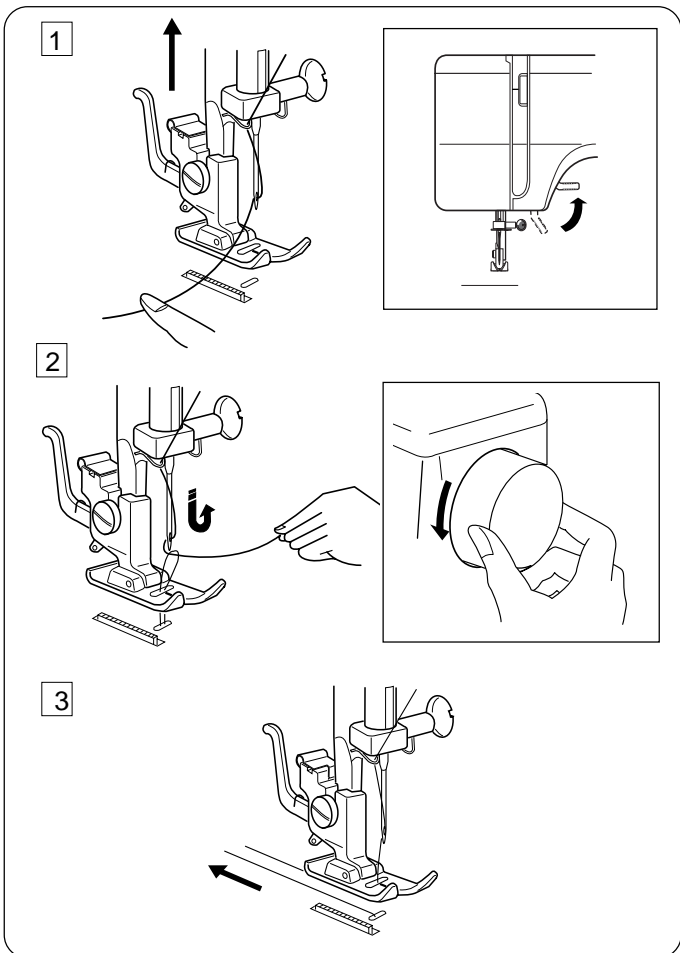

## Drawing Up Bobbin Thread

- 1 Raise the presser foot and hold the needle thread lightly with your left hand.
- 2 Turn the handwheel one complete turn toward you and raise the needle to its highest position.  
Pull the needle thread to pick up a loop of the bobbin thread.
- 3 Pull 15 cm (6") of both threads back and under the presser foot.

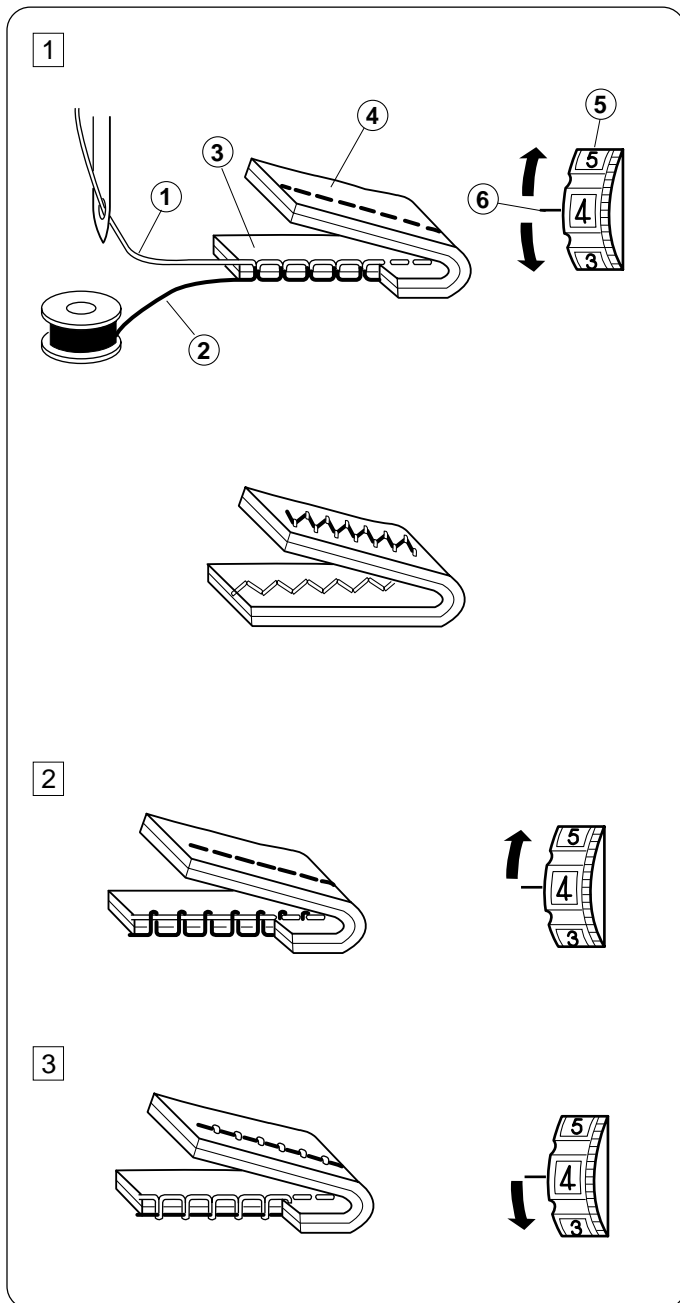

## Balancing Needle Thread Tension

### 1 Correct tension

The thread tension is adjusted depending on the sewing materials, layers of fabric and other sewing conditions.

- \* The ideal straight stitch has threads looked between two layers of fabric, as illustrated (magnifies to show detail).
- \* For an ideal zigzag stitch, the bobbin thread does not show on the right side (top side) of the fabric, and the needle thread shows slightly on the wrong side (bottom side) of the fabric.

- ① Needle thread (Top thread)
- ② Bobbin thread (Bottom thread)
- ③ Right side (Top side) of fabric
- ④ Wrong side (Bottom side) of fabric
- ⑤ Thread tension dial
- ⑥ Setting mark

### 2 Needle thread tension is too tight

If the bobbin thread (bottom thread) appears on the right side (top side) of the fabric, loosen the needle thread tension by moving the dial to a lower number.

### 3 Needle thread tension is too loose

If the needle thread (top thread) appears on the wrong side (bottom side) of the fabric, tighten the needle thread tension by moving the dial to a higher number.

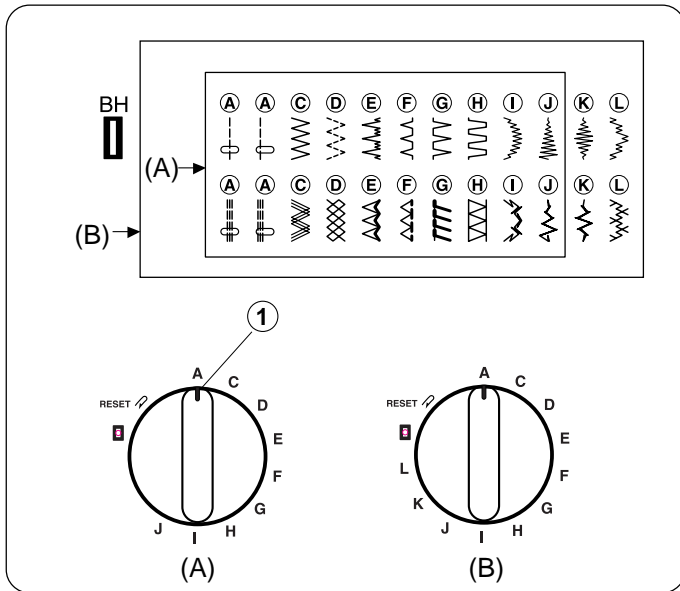

### Pattern Selector Dial

Raise the needle and presser foot. Turn the pattern selector dial to set the setting mark at the symbol corresponding to the desired pattern.

① Setting mark

(A): Model 419S

(B): Model 423S

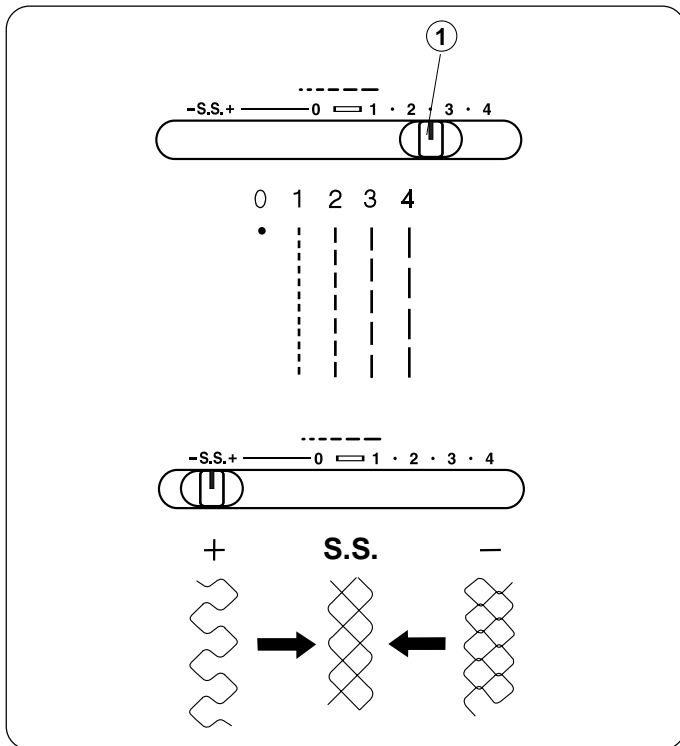

### Stitch Length Control

Slide the stitch length control to set the setting mark at the desired stitch length.

The higher the number, the longer the stitch

① Setting mark

- "  " is the recommended setting for buttonhole stitching.
- Adjust the stitch length control in the 0.5–4 range when you sew the zigzag stitch.
- Set the stitch length control at "S.S." to sew the stretch stitch pattern.
- If the stretch stitch pattern is uneven, slide the stitch length control in the direction of "-" to compress it, or "+" to expand it.

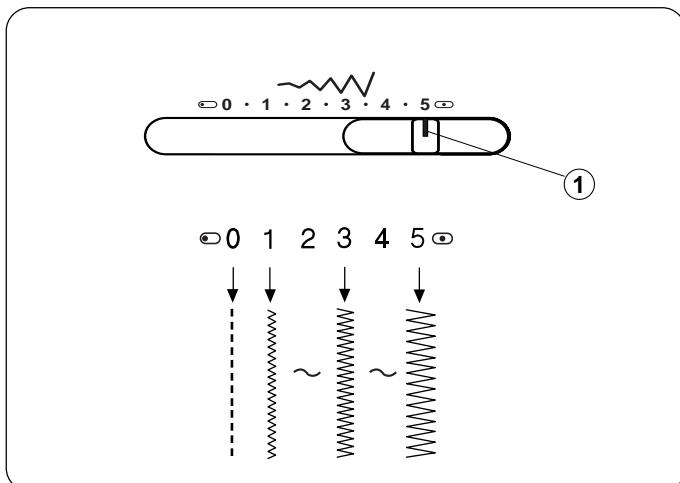

### Stitch Width Control

Slide the stitch width control to set the setting mark at the desired stitch width.

The higher the number, the wider the stitch width

① Setting mark

When the stitch width is narrow, the right side of the pattern is cut off.

(Example: Pattern E)

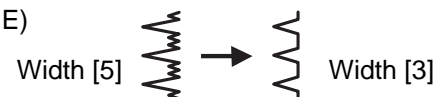

**Note :** Raise the needle above the fabric, when you slide the stitch width control.

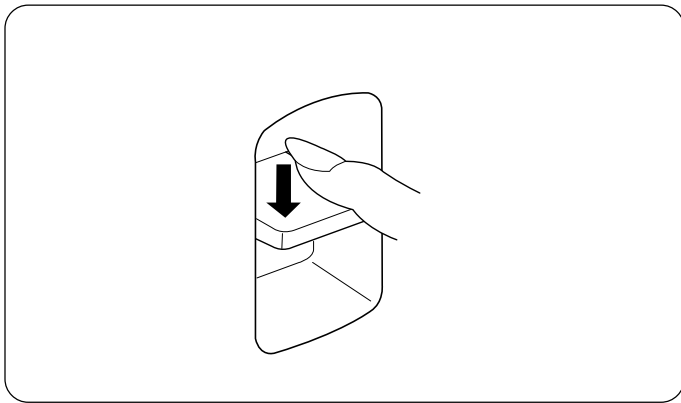

### Reverse Stitch Button

As long as you keep the reverse stitch button depressed, the machine sews backwards.

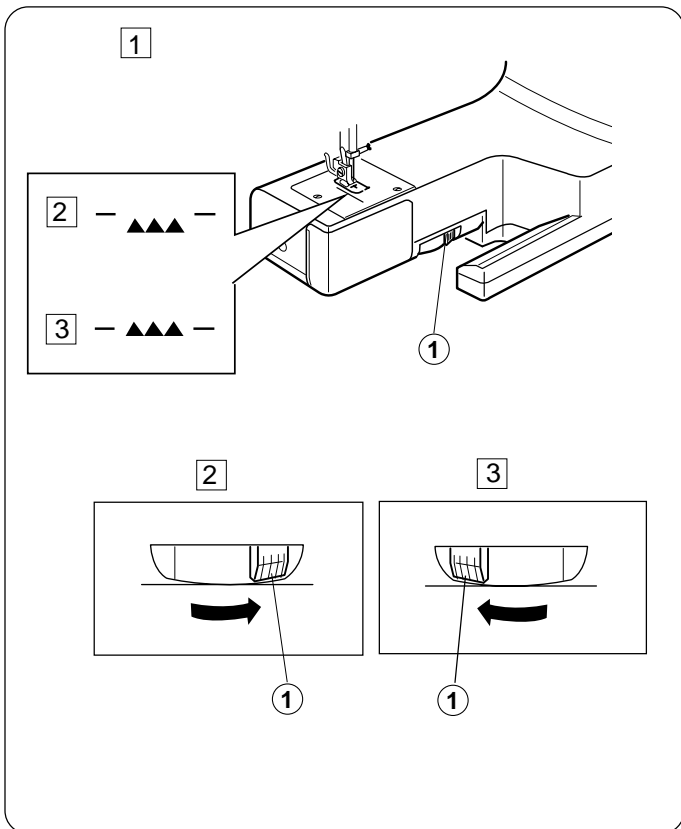

### Dropping the Feed Dog

- 1 Remove the extension table.  
Raise the presser foot.
- 2 To drop the feed dog, push the lever to the right .
- ① Drop feed lever
- 3 To raise the feed dog, push the lever to the left.

- \* The feed dog must be up for normal sewing.
- \* The feed dog will return to the up position when the machine starts running.



## SECTION 3. BASIC SEWING

### Straight Stitch Sewing

- ① Pattern selector: A
- ② Presser foot: Zigzag foot
- ③ Thread tension: 2-6
- ④ Stitch length: 1.5-4
- ⑤ Stitch width: ◯ (0) or ◐ (5)

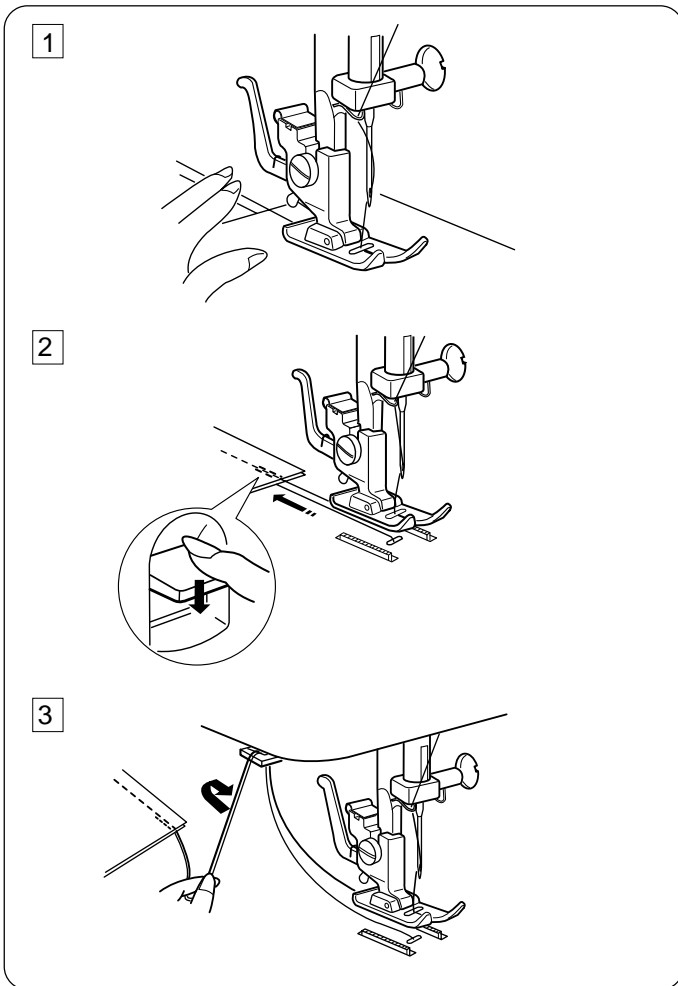
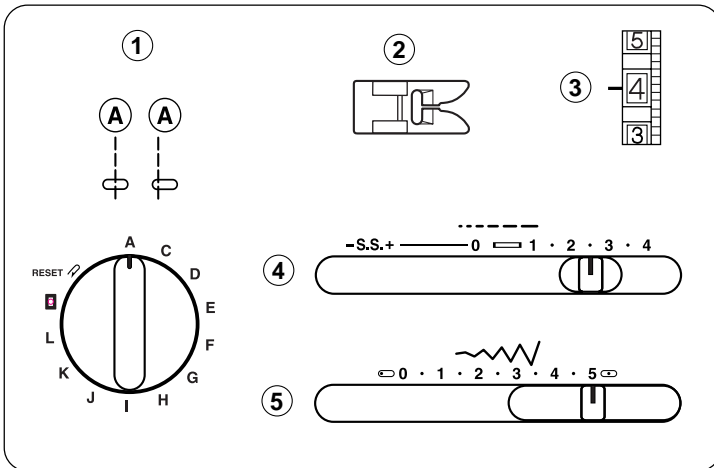

- 1 Raise the presser foot and position the fabric with its edge lining up with a seam guide line on the needle plate.  
Lower the needle into the fabric.  
Lower the presser foot and smooth the threads toward the back. Depress the foot control.  
Gently guide the fabric along the guide line letting the fabric feed by itself.

- 2 For fastening the end of seams, press the reverse stitch button and sew several reverse stitches.  
Raise the presser foot and remove the fabric, drawing the threads to the back.

- 3 Draw the threads up and into the thread cutter.  
The threads are cut the proper length for starting the next seam.

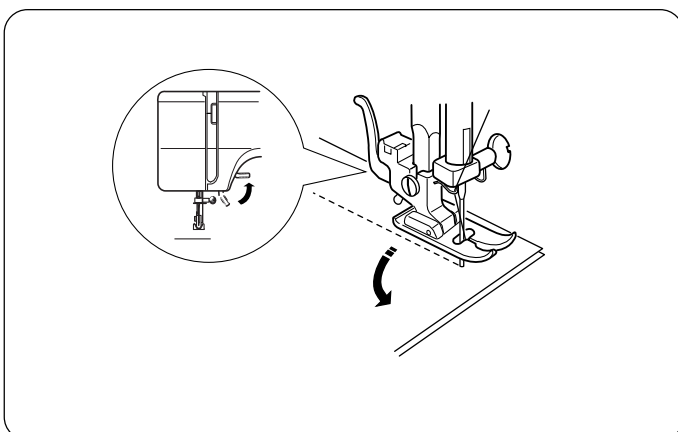

### To Change Sewing Direction

- Stop the machine and turn the handwheel toward you to bring the needle down into the fabric.  
Raise the presser foot.  
Pivot the fabric around the needle to change sewing direction as desired. Lower the presser foot and continue sewing.

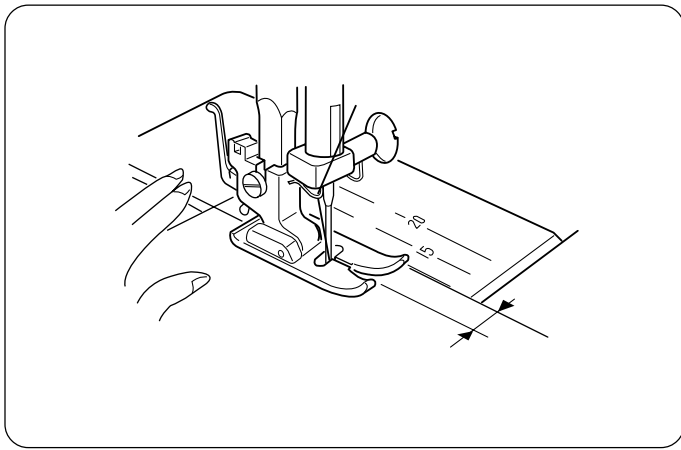

### Seam Guides Line

The numbers on the needle plate indicate the distance between the center needle position and the line.

The numbers in front are millimeters.

The numbers in back are fractions of an inch.

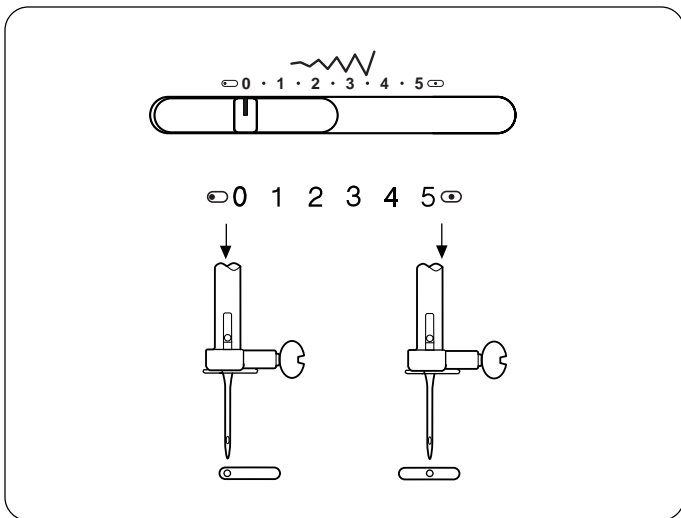

### Variable Needle Position

When the straight stitch (pattern A) is selected, you can move the needle drop position between center and left by sliding the stitch width control.

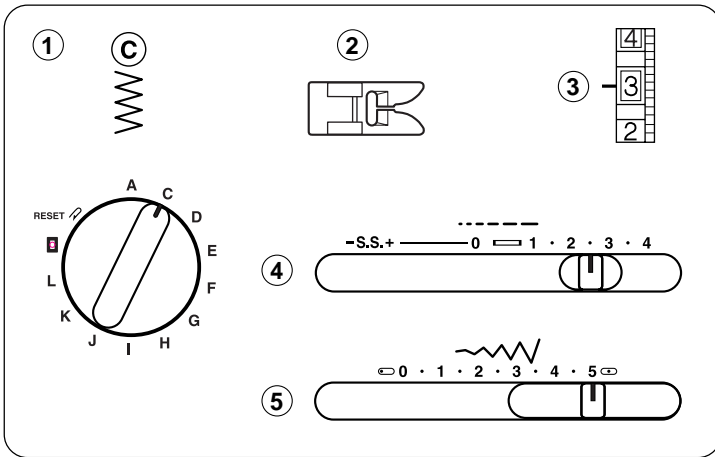

## Zigzag Stitching

- ① Pattern selector: C
- ② Presser foot: Zigzag foot
- ③ Thread tension: 2–5
- ④ Stitch length: 0.5–4
- ⑤ Stitch width: 5

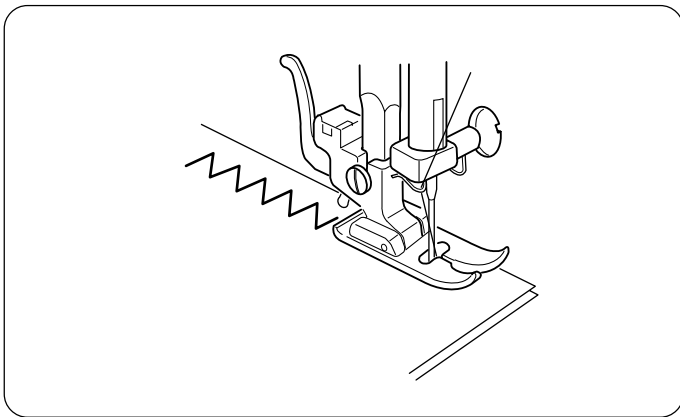

Simple zigzag stitching is widely used for overcasting, sewing on buttons etc.

## SECTION 4. UTILITY STITCHING

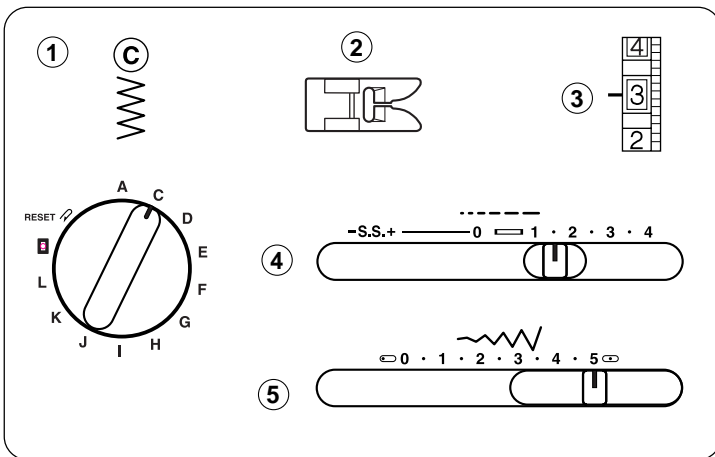

### Overcasting

- ① Pattern selector: C
- ② Presser foot: Zigzag foot
- ③ Thread tension: 1–4
- ④ Stitch length: 1–2
- ⑤ Stitch width: 5

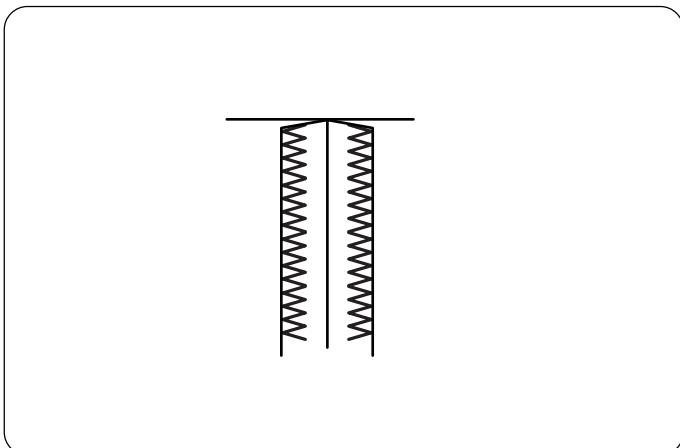

The zigzag stitch is used on the seam allowance to prevent fabric from fraying at raw edges.

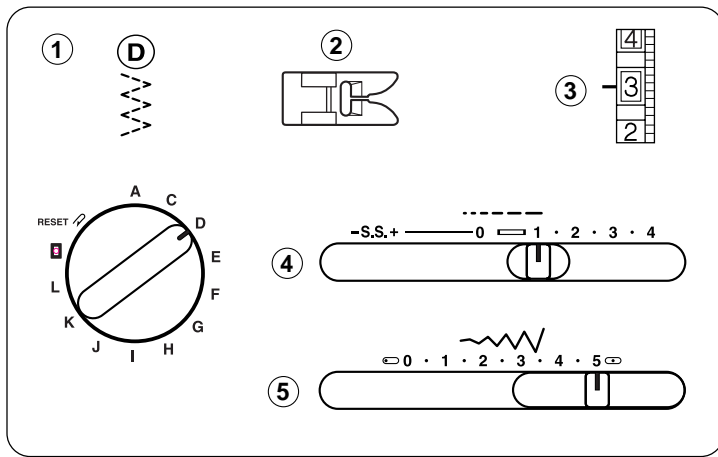

### Tricot Stitch

- ① Pattern selector: D
- ② Presser foot: Zigzag foot
- ③ Thread tension: 1-4
- ④ Stitch length: 0.5-1.5
- ⑤ Stitch width: 5

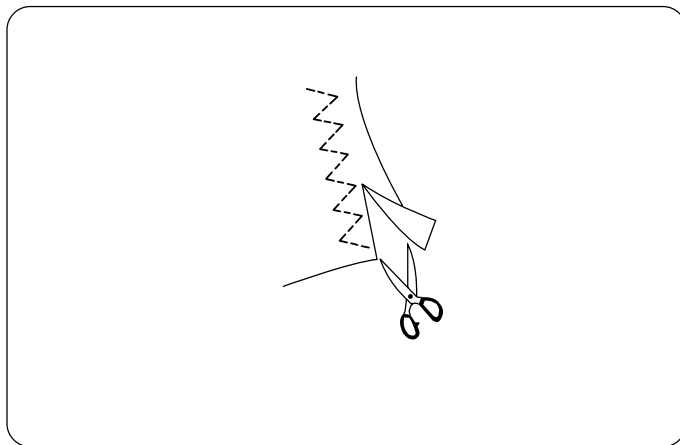

This stitch is used to finish the raw edge on synthetics and other fabrics that tend to pucker.

Place your fabric to allow 1.6 cm (5/8") seam.

Trim the seam allowance after sewing.

**Note :** Be careful not to cut the stitches.

It is also handy for darning and mending tears.

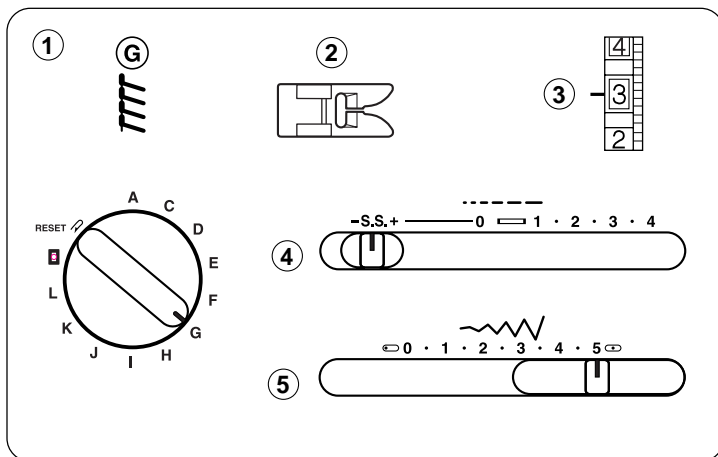

### Knit Stitch

- ① Pattern selector: G
- ② Presser foot: Zigzag foot
- ③ Thread tension: 1-4
- ④ Stitch length: S.S.
- ⑤ Stitch width: 5

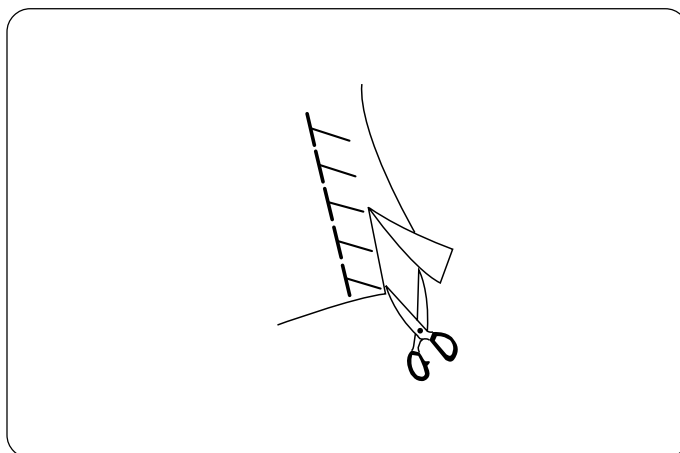

This knit stitch is ideal for sewing swimwear and stretch velour because it provides the greatest amount of elasticity and strength.

Place your fabric to allow a 1.6 cm (5/8") seam.

Trim the seam allowance after sewing.

**Note :** Be careful not to cut the stitches.

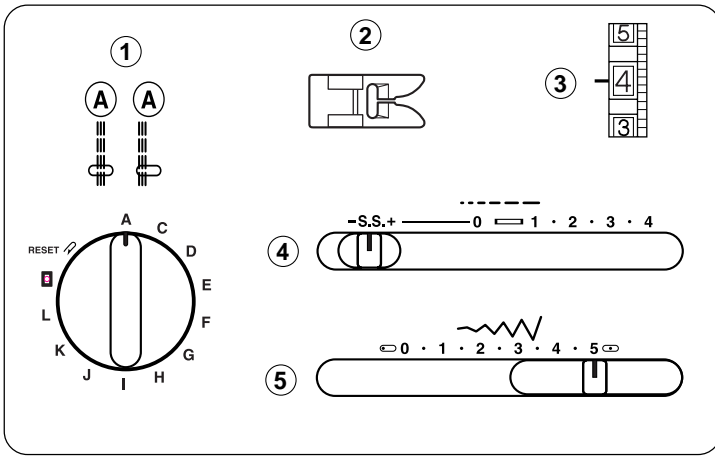

## Straight Stretch Stitch

- ① Pattern selector: A
- ② Presser foot: Zigzag foot
- ③ Thread tension: 2-6
- ④ Stitch length: S.S.
- ⑤ Stitch width: 0 (0) or 5 (5)

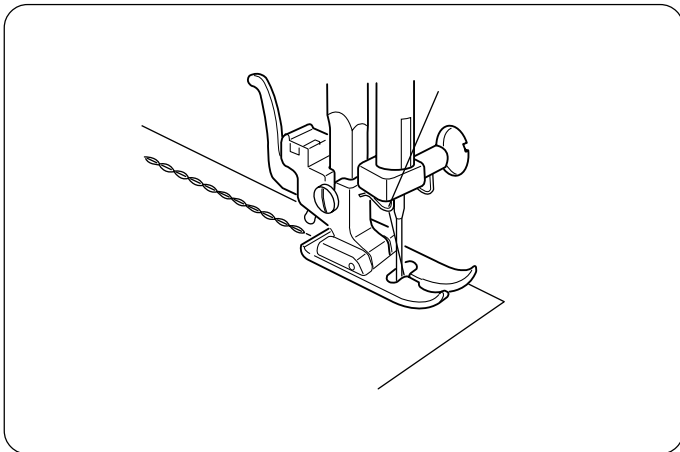

The stitch is sewn with two stitches forward and one stitch backward forming a seam that does not rip easily.

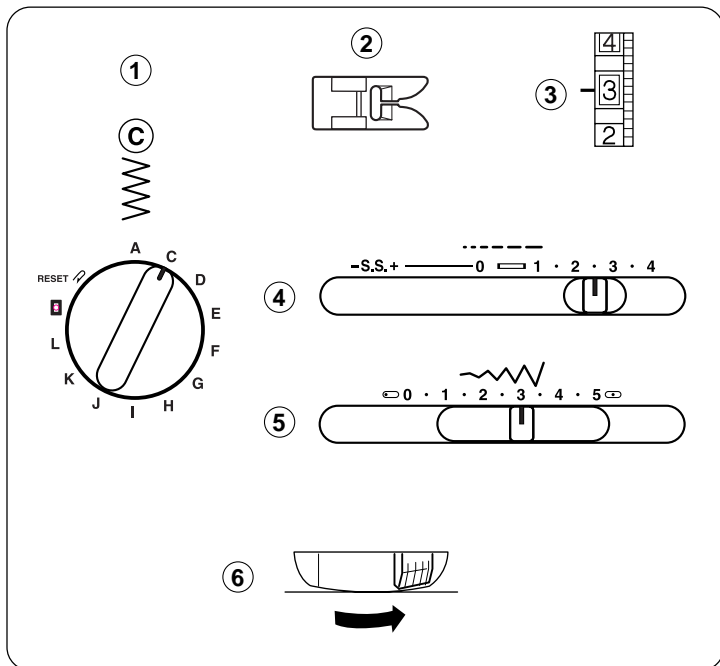

## Sewing on Buttons

- ① Pattern selector: C
- ② Presser foot: Zigzag foot
- ③ Thread tension: 1–3
- ④ Stitch length: Any
- ⑤ Stitch width: Adjust as necessary
- ⑥ Feed dog: Dropped

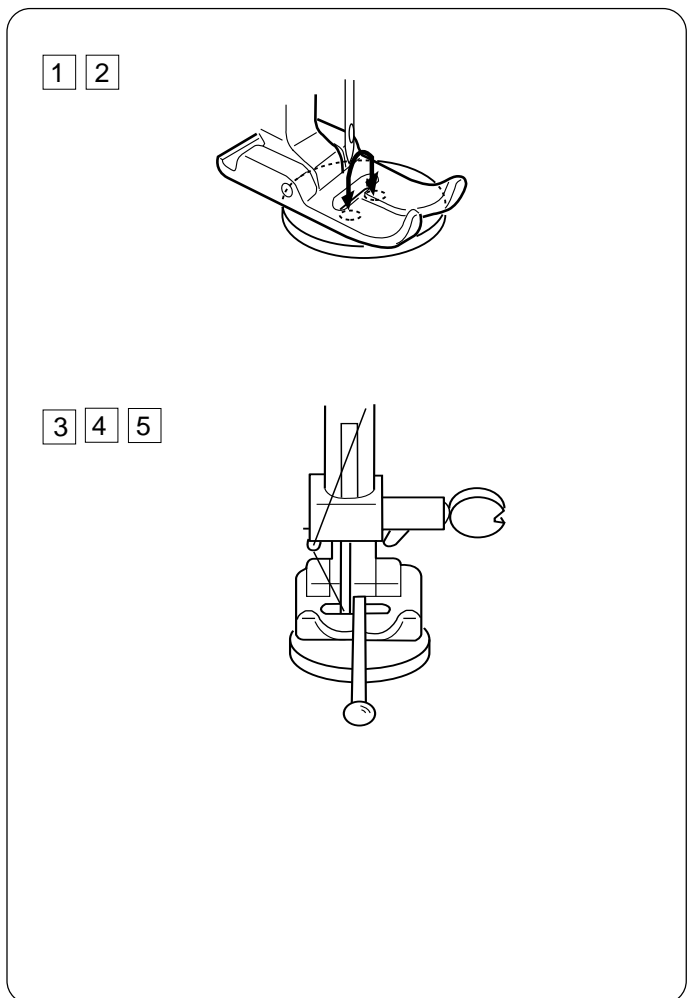

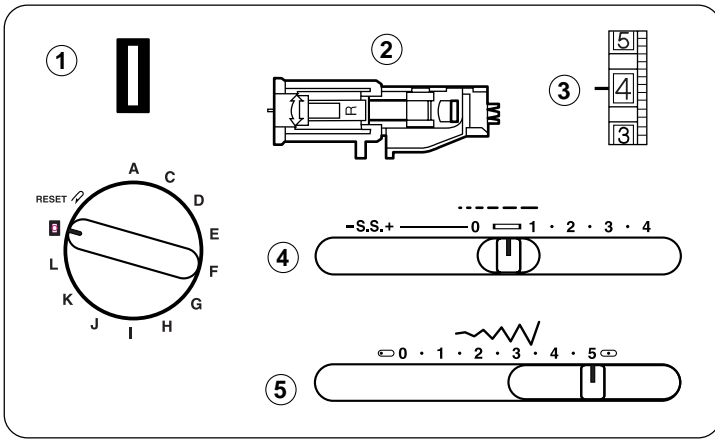

- 1 Push the drop feed lever to the right to lower the feed dog.  
Set the pattern selector dial at "C" and stitch width control at 0.  
Place the button under the foot. Unthread the needle and turn the handwheel slowly to lower the needle into the left hole on the button.  
Align the right hole on the button with the slot of the foot and lower the foot to hold the button in place.
- 2 Raise the needle and adjust the stitch width so that the needle enters into the right hole on the button.
- 3 Rethread the needle and sew 10 stitches. A pin can be placed on top of the foot to form a shank.
- 4 Raise the needle and set the stitch width control to 0 then sew a few stitches to lock the seam.
- 5 Raise the foot and trim the excess thread.

**Note:** When button sewing is finished, raise the feed dog.



## Buttonhole

- ① Pattern selector: 
- ② Presser foot: Automatic buttonhole foot
- ③ Thread tension: 1-5
- ④ Stitch length:  (0.5-1)
- ⑤ Stitch width: 5

- \* The size of buttonhole is automatically set by placing the button in the automatic buttonhole foot.
- \* The button holder of the foot takes a button size up to 2.5 cm (1") in diameter.
- \* Make a test buttonhole on a sample duplicating the fabric, interfacing and seams of the actual garment.
- \* Place the button on the fabric sample and mark the top and bottom to determine the position of buttonhole.
- \* Use interfacing on stretch fabrics.

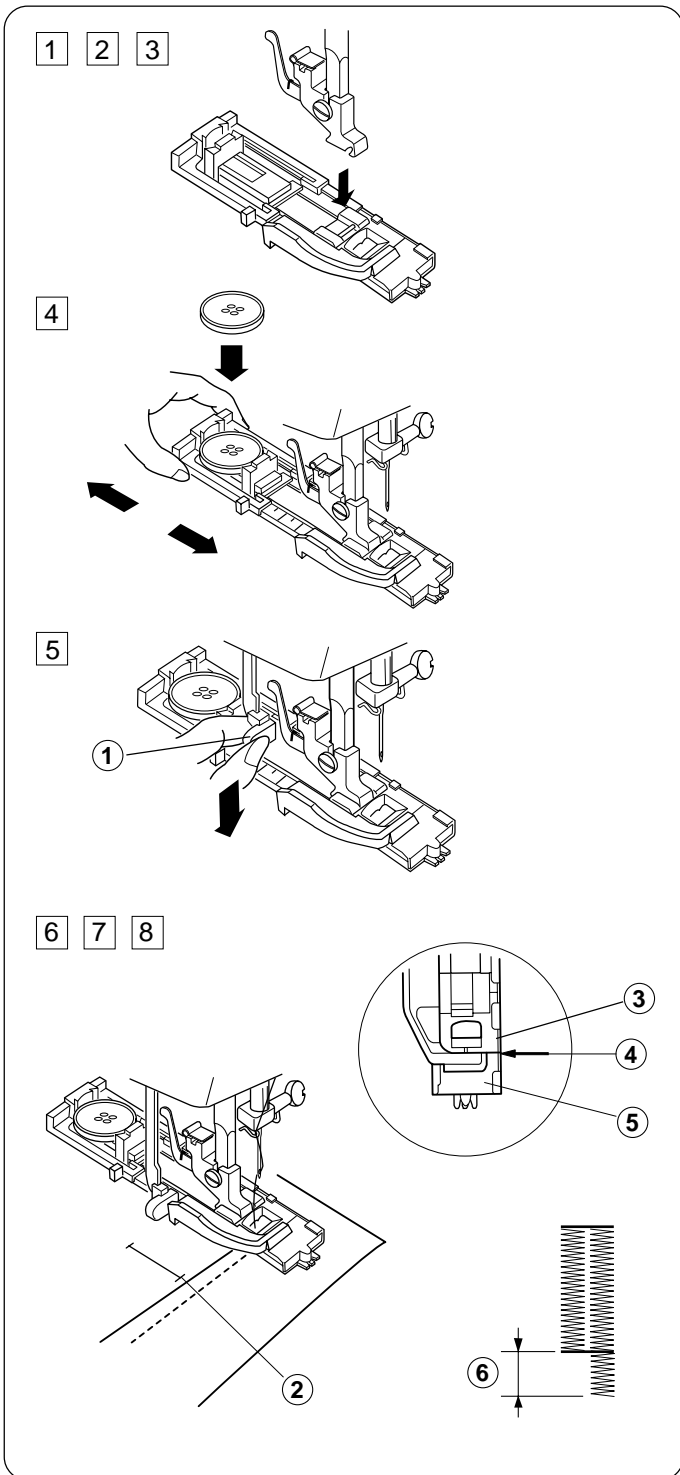

- 1 Turn the handwheel toward you to raise the needle to its highest position.  
Raise the presser foot lifter.
- 2 Select the pattern "BH" by turning the pattern selector dial.  
If the BH pattern is already selected, reset the dial once according to the procedure in 12.
- 3 Attach the automatic buttonhole foot.
- 4 Pull the button holder to the back, and place the button in it. Push back the button holder toward you as far as it will go.
- 5 Pull the buttonhole lever downward as far as it will go.  
① Buttonhole lever
- 6 Insert fabric under the foot.  
Turn the handwheel slowly towards you with your right hand until the needle goes down and continue turning handwheel until the take-up lever is at its highest position.
- 7 Remove the fabric to the left to draw both threads to the left.
- 8 Insert the garment under the foot, and lower the needle at the starting point.  
Then lower the automatic buttonhole foot.

**Note :** Make sure there is no gap between the slider and the spring holder. If there is a gap, the length of the rows will be different, as shown.

- ② Starting point
- ③ Slider
- ④ There should be no gap
- ⑤ Spring holder
- ⑥ Difference

9

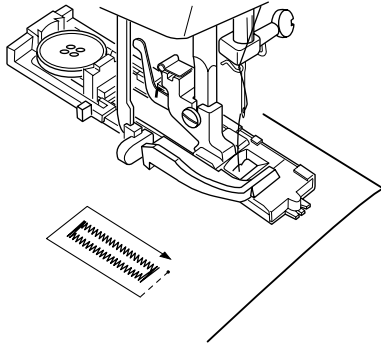

10 11

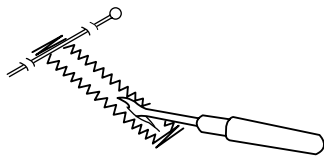

12

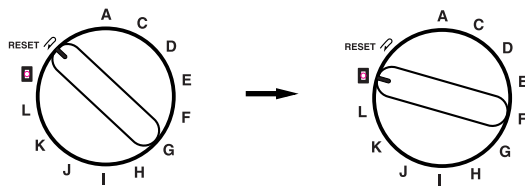

13

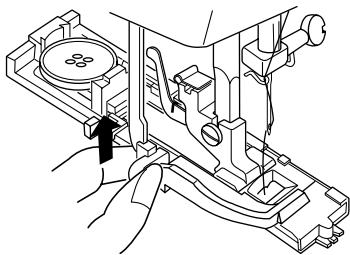

9

Sew slowly and stop the machine when a buttonhole is completed.

\*

The machine sews the front bartack and left row first, then the back bartack and right row.

10

Cut both needle and bobbin threads leaving about 10 cm (4") thread ends.

Draw the needle thread to wrong side of fabric by pulling the bobbin thread.

Then, knot the threads.

11

Insert a pin inside the bartack.

Then cut the opening with seam ripper.

Take care not to cut the stitches.

12

To repeat buttonhole sewing, turn the stitch selector to **RESET**, then back to **I** again, as shown.

Now, simply step on the foot control to sew an identical buttonhole.

13

When buttonhole sewing is finished, push the buttonhole lever upward as far as it will go.

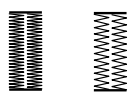

- S.S. + 0 1 2 3 4



● **To adjust buttonhole stitch density.**

Set the stitch length control between 0.5 and 1.0 to adjust the buttonhole stitch density.



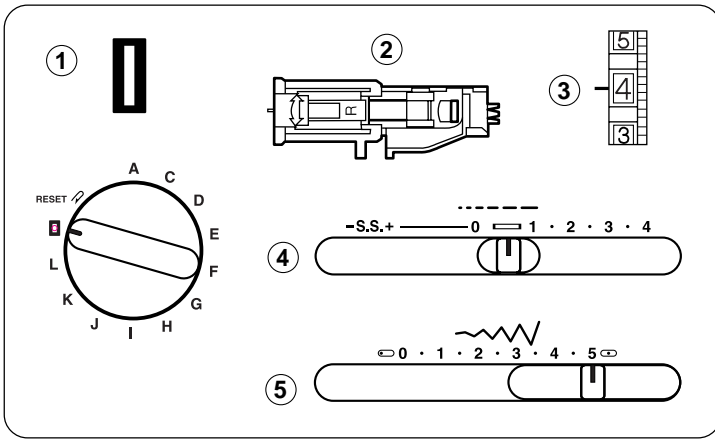

## Corded Buttonhole

- ① Pattern selector: Automatic buttonhole foot
- ② Presser foot: Automatic buttonhole foot
- ③ Thread tension: 1-5
- ④ Stitch length: (0.5-1)
- ⑤ Stitch width: 5

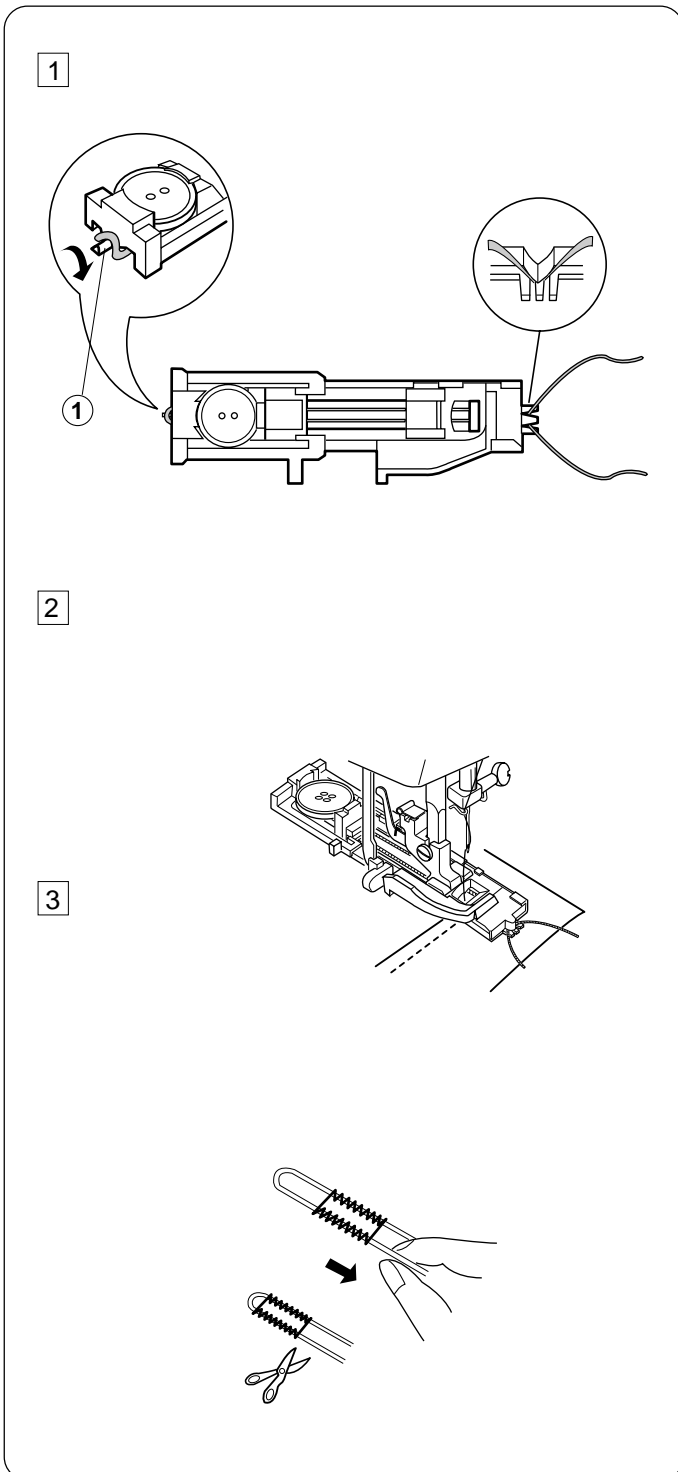

① Use the same procedure as automatic buttonhole.

- \* Set the stitch width to match with the thickness of the cord used.

With the buttonhole foot raised, hook the filler cord on the spur at the back of the buttonhole foot.

Bring the ends toward you under the buttonhole foot, clearing the front end.

Hook the filler cord into the forks on the front of the automatic buttonhole foot to hold them tight.

Lower the needle into the garment where the buttonhole will start and lower the foot.

① Spur

② Depress the foot control gently and sew the buttonhole. Each side of the buttonhole and the bartacks will be sewn over the cord.

Remove the fabric from the machine and cut the sewing threads only.

③ Pull the left end of the filler cord to tighten it. Thread the end through a darning needle, draw to the wrong side of the fabric and cut.

- \* To cut the buttonhole opening, refer to the Instructions on page 21.

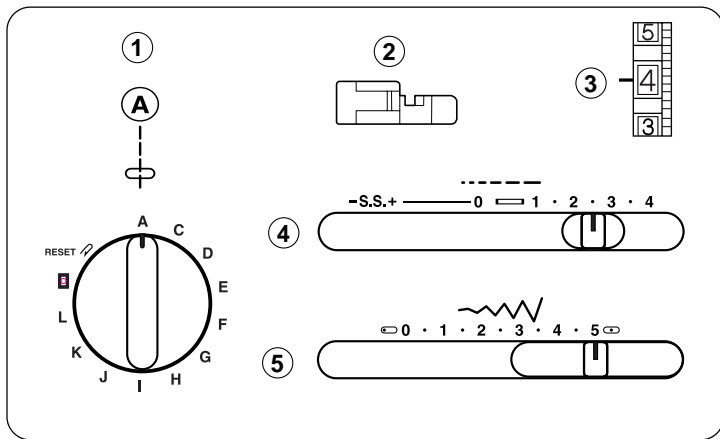

## Zipper Application

- ① Pattern selector: A
- ② Presser foot: Zipper foot
- ③ Thread tension: 3 – 6
- ④ Stitch length: 1.5 – 4
- ⑤ Stitch width: (5)

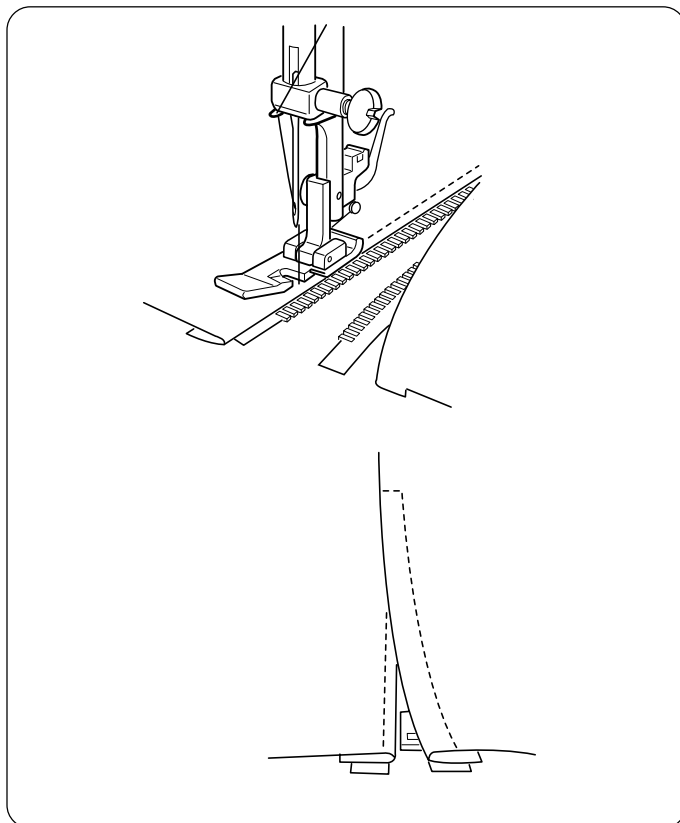

Pin or baste zipper tape to fabric and place it under the foot. Smooth the threads toward the back and lower the foot. To sew the left side of the zipper, guide the zipper teeth along the edge of the foot and stitch through the garment and zipper tape. Turn the fabric and sew the other side of the zipper in the same way as you did the left side.

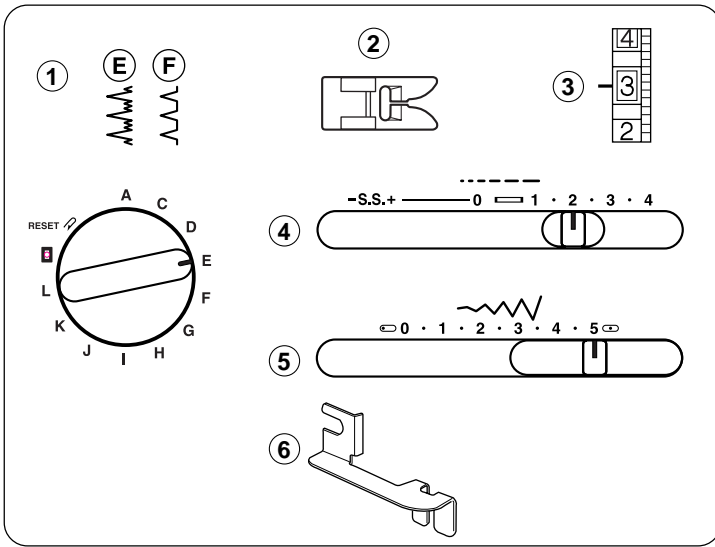

## Blind Stitch Hemming

- ① Pattern selector: E or F
- ② Presser foot: Zigzag foot
- ③ Thread tension: 2-4
- ④ Stitch length: 1-3
- ⑤ Stitch width: 5
- ⑥ Hem guide

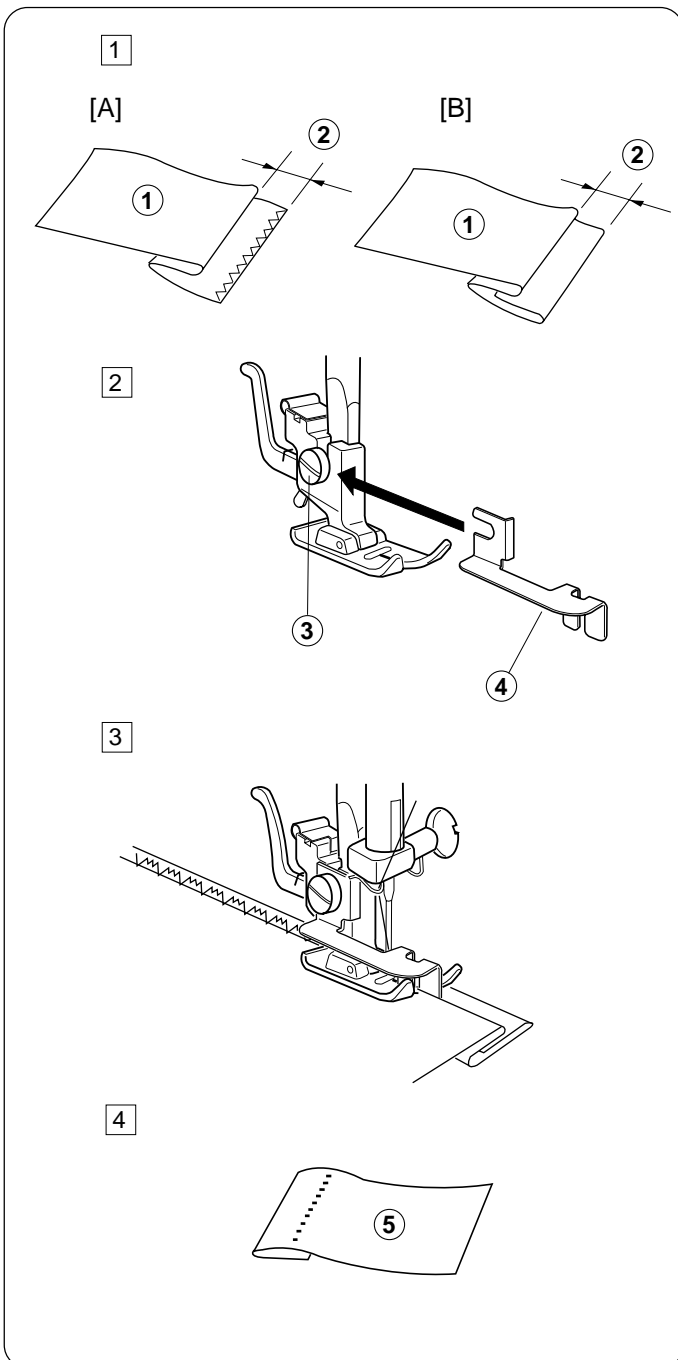

- ① Fold up the hem and fold it back to from a 0.4 to 0.7cm (1/4") allowance as illustrated.

- ① Wrong side of the fabric
- ② 0.4 to 0.7 cm (1/4")

[A] Heavy weight fabrics (The raw edge should be overcast.)

[B] Fine or medium weight fabrics

- ② Lower the presser foot, then loosen the foot holder screw to place the hem guide between the screw and the shank of foot holder.  
Tighten the screw making sure the wall of hem guide is placed between the toes of the presser foot.

- ③ Screw
- ④ Hem guide

- ③ Raise the presser foot and place the fabric under the foot so that the folded edge rests against the wall of the hem guide.  
Lower the foot, then stitch slowly for better control so that the needle just pierces the folded edge when it swings to the extreme left side.  
Sew guiding the folded edge along the wall of the hem guide.

- ④ Open the fold flat.
- ⑤ Right side of the fabric

\* If the needle drops far left, the stitches will show on the right side of the fabric.

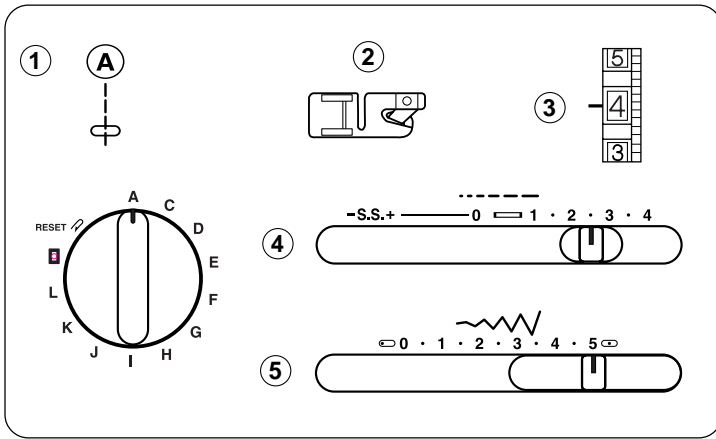

## Rolled Hem

- ① Pattern selector: A
- ② Presser foot: Hemmer foot
- ③ Thread tension: 2-6
- ④ Stitch length: 1.5-4
- ⑤ Stitch width: 5

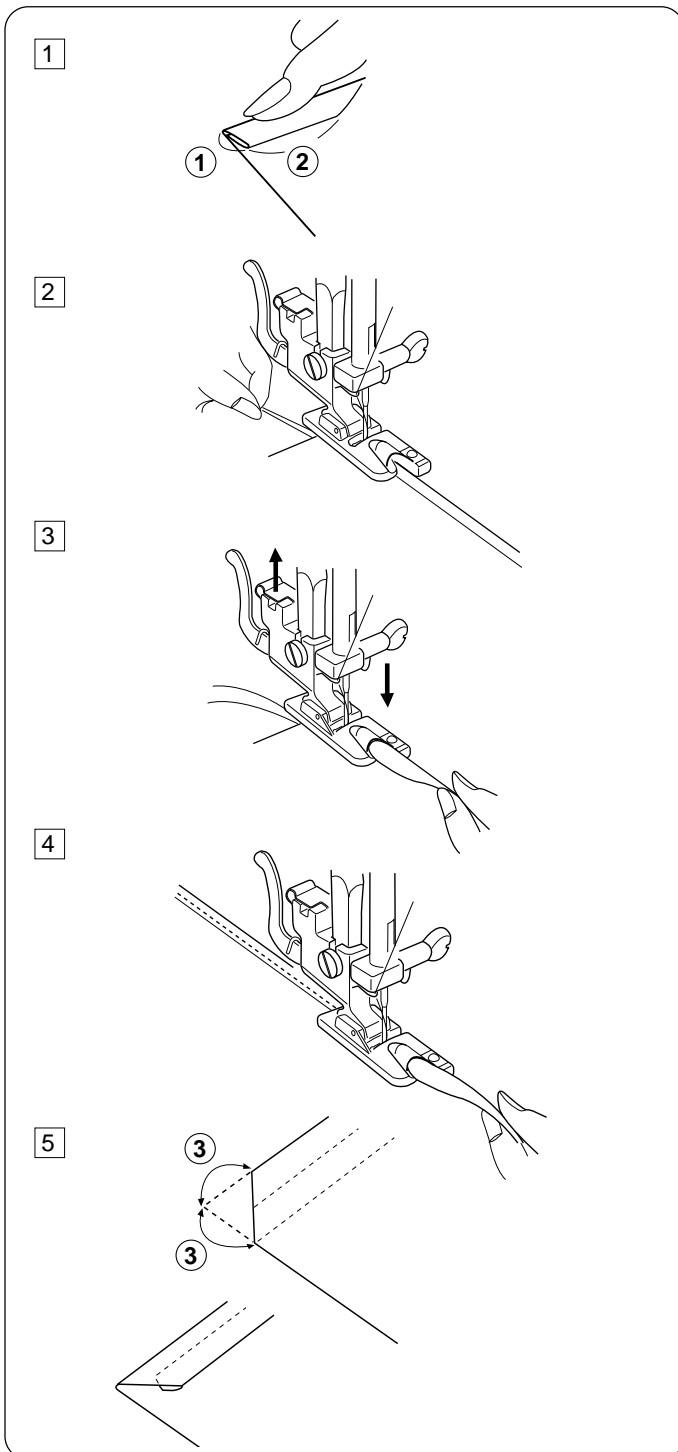

- ① Make a double 0.25 cm (1/8") fold approximately 8 cm (3") in length.
  - ① 0.25 cm (1/8")
  - ② 8 cm (3")
- ② Lower the needle into the fabric at the point where sewing is to begin, then lower the hemmer foot. Sew 3 or 4 stitches while pulling the needle and bobbin threads.
- ③ Lower the needle into the fabric and lift the hemmer foot. Insert the folded portion of the fabric into the curl of the hemmer foot.
- ④ Lower the hemmer foot, then sew by lifting up the edge of the fabric to keep it feeding into the curl smoothly and evenly.
- ⑤ Trim about 0.7 cm (1/4") from corners as illustrated, to reduce bulk.
  - ③ 0.7cm (1/4")

## SECTION 5. DECORATIVE STITCHING

### Shell Tuck

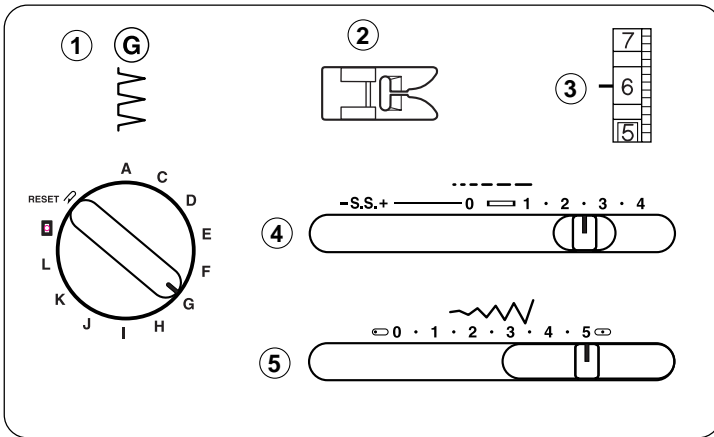

- ① Pattern selector: G
- ② Presser foot: Zigzag foot
- ③ Thread tension: 6-8
- ④ Stitch length: 2-3
- ⑤ Stitch width: 5

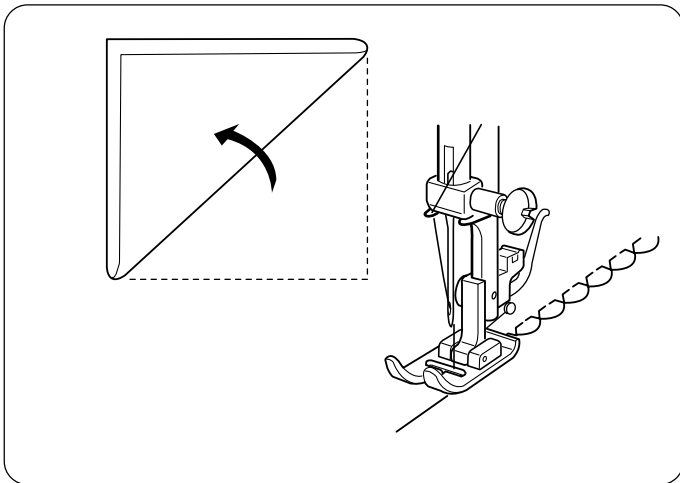

Fold the fabric in bias.

Place the folded edge along the slot of foot.

The needle should fall off the edge of the fabric on the right forming tucks.

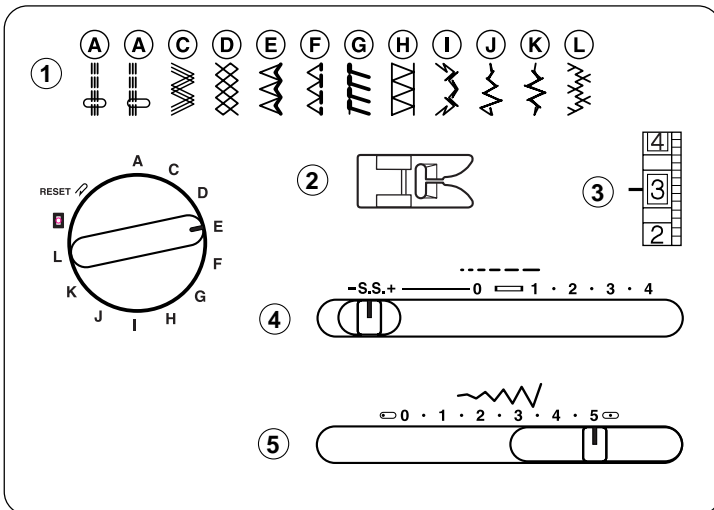

### Stretch Stitch Patterns

- ① Pattern selector: A-J (Model 419S)  
A-L (Model 423S)
- ② Presser foot: Zigzag foot
- ③ Thread tension: 1-4
- ④ Stitch length: S.S.
- ⑤ Stitch width: 5

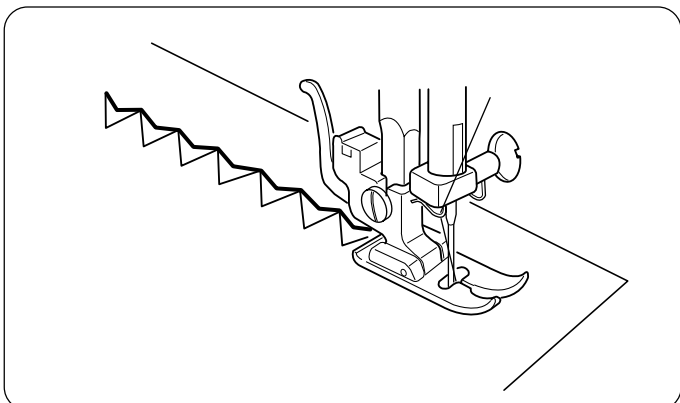

If forward and reverse feeds become unbalanced due to the type of fabric, adjust the balance by slide the stitch length control as follows:

If patterns are compressed, slide the stitch length control toward " + ".

If patterns are drawn, slide the stitch length control toward " - ".

(See page 12 )

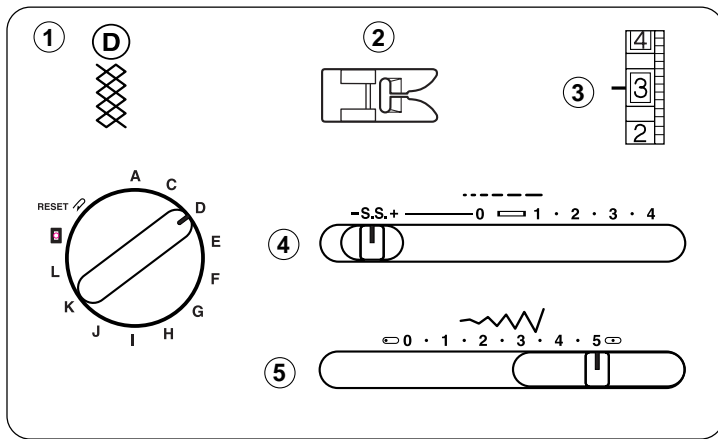

### Smocking

- ① Pattern selector: D
- ② Presser foot: Zigzag foot
- ③ Thread tension: 1-4
- ④ Stitch length: S.S.
- ⑤ Stitch width: 5

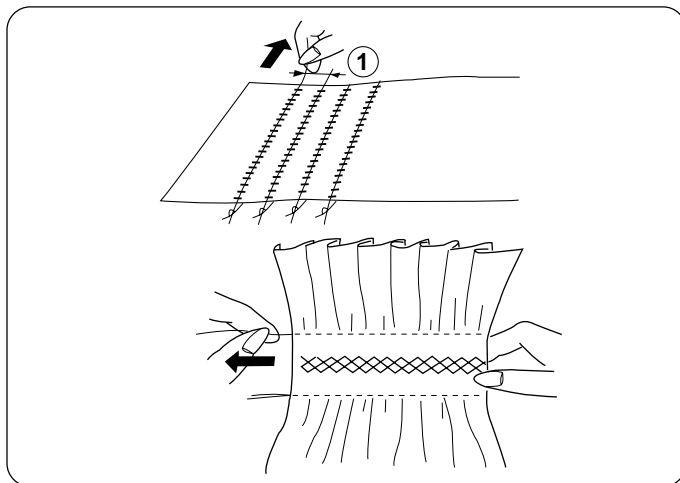

With the stitch length at "4", sew straight stitching lines 1 cm (3/8") apart, across the area to be smocked.

**Note :** Loosen the needle thread tension to make gathering easier.

Knot the threads along one edge. Pull the bobbin threads and distribute the gathers evenly.

Secure the threads at the other end.

Sew the decorative stitch pattern between the gathering stitches.

Pull out the gathering stitches.

- ① 1 cm (3/8")

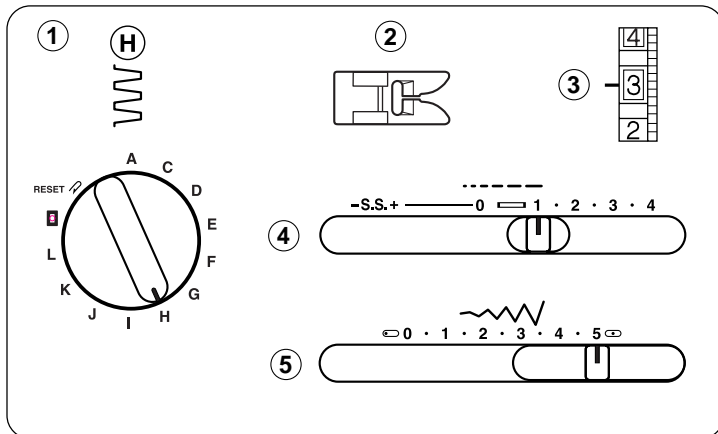

### Box Stitching

- ① Pattern selector: H
- ② Presser foot: Zigzag foot
- ③ Thread tension: 1-4
- ④ Stitch length: 0.5-2
- ⑤ Stitch width: 5

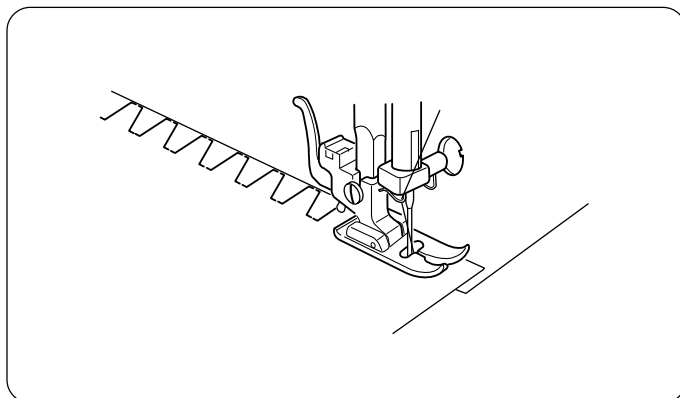

Use this stitch to join heavy weight fabrics.

Overlap two raw edges together and use this stitch to join them.

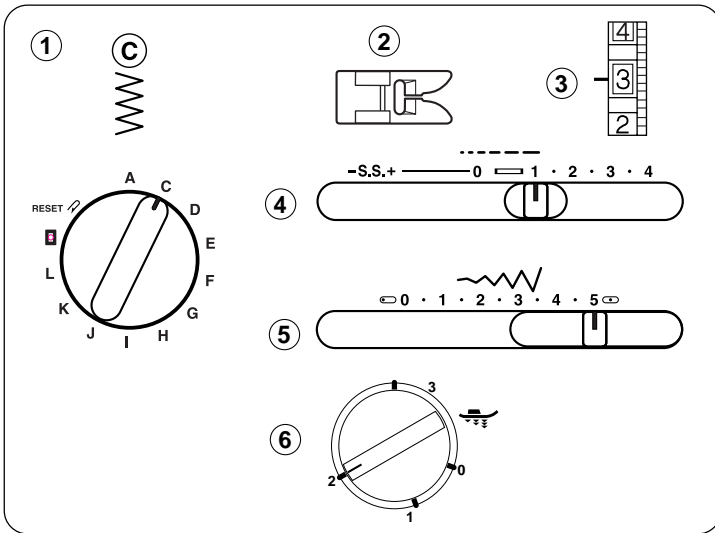

## Applique

- ① Pattern selector: C
- ② Presser foot: Zigzag foot
- ③ Thread tension: 1-4
- ④ Stitch length: 0.5-1
- ⑤ Stitch width: 5
- ⑥ Presser dial: 2

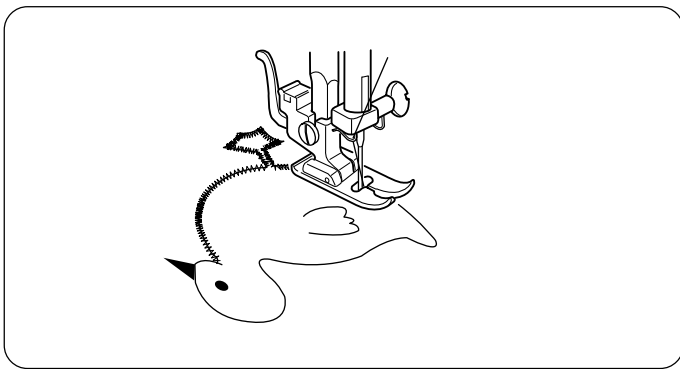

Baste (or fuse with iron-on fabric joiner) applique pieces on the fabric. Stitch around the applique making sure the needle falls along the outer edge of the applique. When sewing corners, lower the needle down into the fabric. Raise the presser foot and pivot fabric to the right or left.

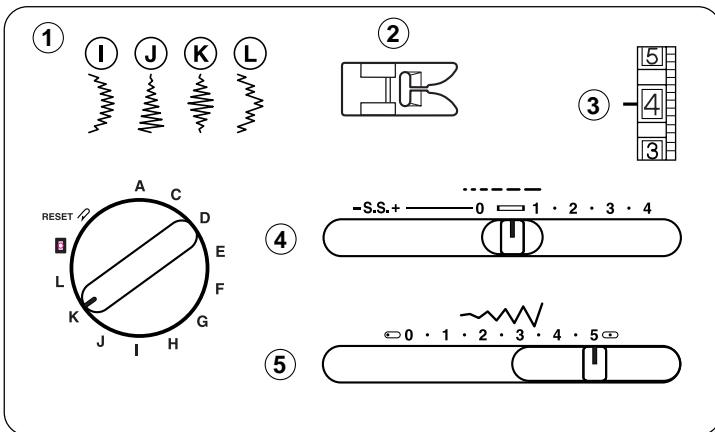

## Decorative Satin Stitch Patterns

- ① Pattern selector: I-J (Model 419S)  
I-L (Model 423S)
- ② Presser foot: Zigzag foot
- ③ Thread tension: 2-5
- ④ Stitch length: 0.5-1
- ⑤ Stitch width: 3-5

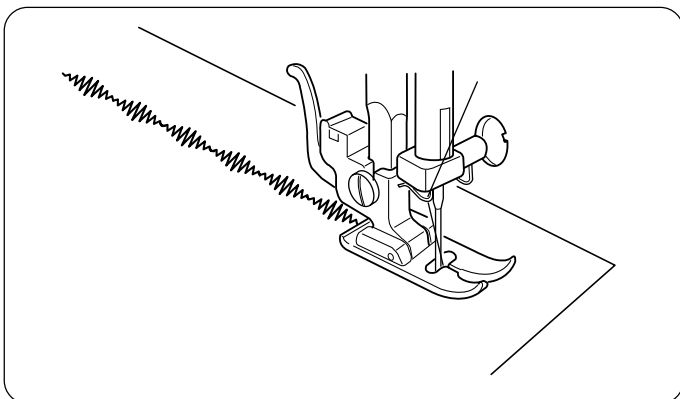

Satin stitches are used for decorative stitches on blankets, linens, tableclothes and napkins.

It is also especially attractive in applique.

**Note:** Use tear-away stabilizer under fabric.

Sew a row of stitches and adjust the thread tension so the needle thread appears on the reverse side of the fabric.

Test the stitch on a sample of the actual fabric first.

## SECTION 6. CARE OF YOUR MACHINE

### Dismantling and Assembling

#### Hook Race Unit

**Note :** Turn off the power switch and/or unplug the machine.

#### To dismantle hook race unit:

Raise the needle to its highest position and open the hook cover. Open the hinged latch of bobbin case and take it out of the machine.

Open the hook race ring holders and remove the hook race ring. Remove the hook.

\* Clean the hook race with a brush and a soft dry cloth.

- ① Bobbin case
- ② Hook race ring holder
- ③ Hook race ring
- ④ Hook
- ⑤ Hook race

#### To assemble hook race unit:

Hold the hook by the center pin and fit it carefully back into the hook race, forming a perfect circle with the shuttle driver.

Attach the hook race ring making sure the bottom pin fits into the notch.

Lock the hook race ring by turning the holders back into position. Insert the bobbin case.

- ⑥ Pin
- ⑦ Notch

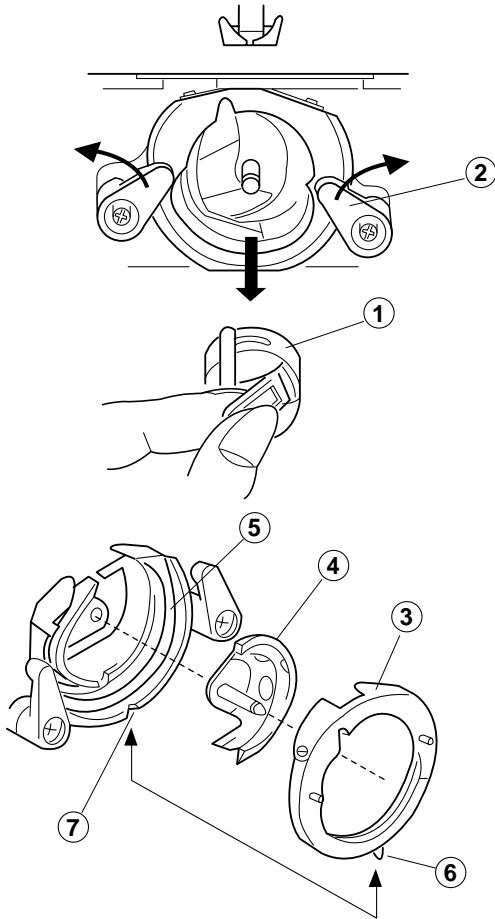

### Cleaning the Feed Dog

**Note :** Turn off the power switch and/or unplug the machine before cleaning the feed dog.

Remove the needle and the presser foot.

Remove the needle plate set screw and remove the needle plate.

With a brush, clean out dust and lint clogging on the feed dog teeth.

Reset the needle plate.

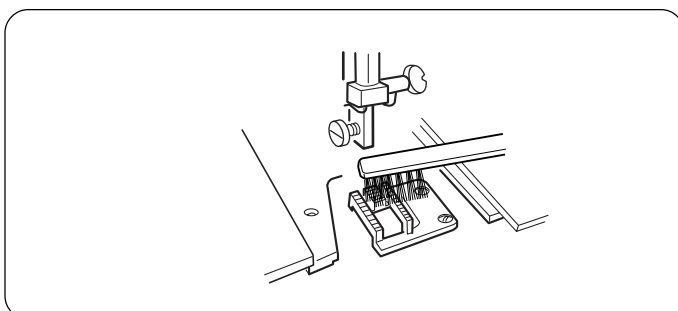
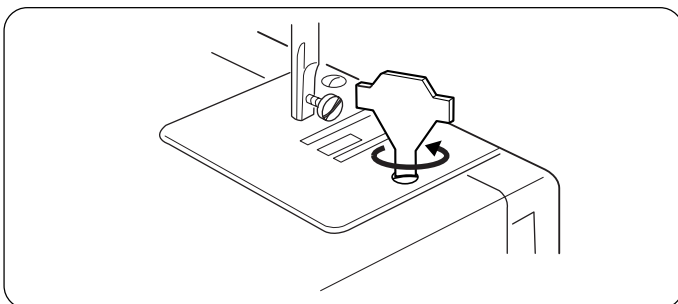



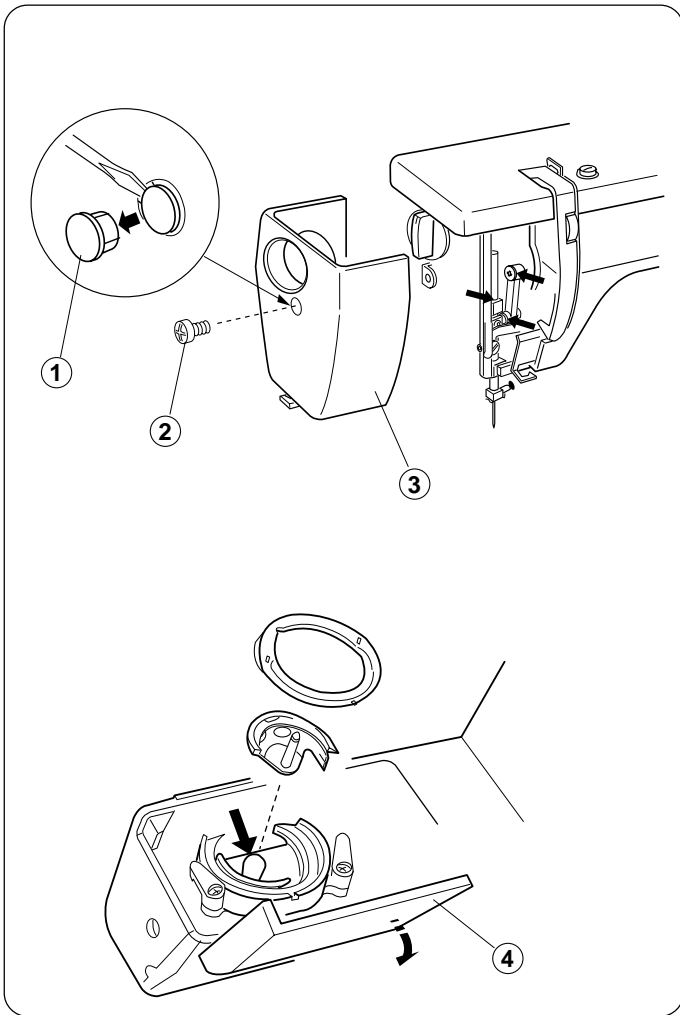

## Oiling the Machine

**Note:** Turn off the power switch when oiling the machine.  
 Oil the points as shown at least once a year.  
 Use good quality sewing machine oil.  
 One or two drops of oil is sufficient.  
 Wipe off excess oil, otherwise it may stain fabric.  
 If machine has not been used for an extended time, oil it before sewing.

### ● Oiling behind the face plate

Remove the cap, screw and face plate.  
 Oil the points indicated in the illustration.

- ① Cap
- ② Screw
- ③ Face plate

### ● Oiling the shuttle hook area

Open the hook cover.  
 Oil the point indicated in the illustration.

- ④ Hook cover

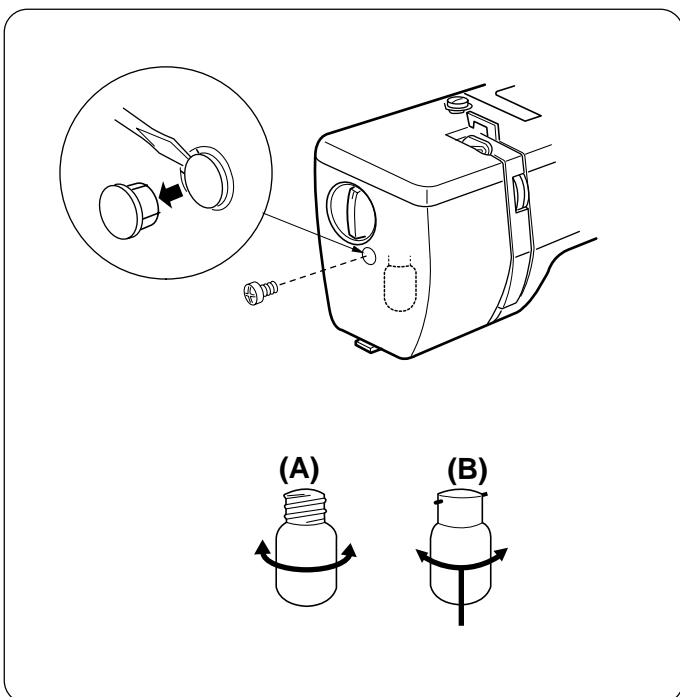

## Sewing Light

The sewing light is located behind the face plate.  
 To change the bulb, take the face plate off the sewing machine by removing the setscrew.

- \* Unplug the power supply before changing the bulb.
- \* Do not dismantle the machine other than explained in this manual.

- (A) ● To remove ..... Turn to the left.
- To replace ..... Turn to the right.
- (B) ● To remove ..... Push and twist to the left.
- To replace ..... Push and twist to the right.

**Warning :** The bulb could be HOT. Protect your fingers when handling it.

## Troubleshooting

Condition	Cause	Reference
<b>The needle thread breaks.</b>	<ol style="list-style-type: none"> <li>1. The needle thread is not threaded properly.</li> <li>2. The needle thread tension is too tight.</li> <li>3. The needle is bent or blunt.</li> <li>4. The needle is incorrectly inserted.</li> <li>5. The fabric is not being drawn to the back when sewing is finished.</li> <li>6. The thread is either too heavy or too fine for the needle.</li> </ol>	<p>See Page 9 See Page 11 See Page 6 See Page 6 See Page 14 See Page 6</p>
<b>The bobbin thread breaks.</b>	<ol style="list-style-type: none"> <li>1. The bobbin thread is not threaded properly in the bobbin case.</li> <li>2. Lint has collected in the bobbin case.</li> <li>3. The bobbin is damaged and doesn't turn smoothly.</li> </ol>	<p>See Page 8 Clean the bobbin case. Exchange bobbin.</p>
<b>The needle breaks.</b>	<ol style="list-style-type: none"> <li>1. The needle is incorrectly inserted.</li> <li>2. The needle is bent or blunt.</li> <li>3. The needle clamp screw is loose.</li> <li>4. The tension of the needle thread is too tight.</li> <li>5. The fabric is not drawn to the back when sewing is finished.</li> <li>6. The needle is too fine for the fabric being sewn.</li> <li>7. The pattern selector dial had been turned while the needle was in the material.</li> </ol>	<p>See Page 6 See Page 6 See Page 6 See Page 11 See Page 14 See Page 6 See Page 12</p>
<b>Skipped stitches</b>	<ol style="list-style-type: none"> <li>1. The needle is incorrectly inserted.</li> <li>2. The needle is bent or blunt.</li> <li>3. The needle and/or threads are not suitable for the work being sewn.</li> <li>4. A BLUE TIPPED needle is not being used for sewing stretch, very fine fabrics and synthetics.</li> <li>5. The needle thread is not threaded properly.</li> </ol>	<p>See Page 6 See Page 6 See Page 6 See Page 6 See Page 9</p>
<b>Seam puckering</b>	<ol style="list-style-type: none"> <li>1. The needle thread tension is too tight.</li> <li>2. The machine is not threaded correctly.</li> <li>3. The needle is too heavy for the fabric being sewn.</li> <li>4. The stitches are too coarse for the fabric being sewn.</li> </ol> <p>* When sewing extremely light weight materials, place a sheet of paper underneath the fabric.</p>	<p>See Page 11 See Page 9 See Page 6 Make the stitches denser.</p>
<b>Stitches form loops below the work</b>	<ol style="list-style-type: none"> <li>1. The needle thread tension is too loose.</li> <li>2. The needle is either too heavy or too fine for the thread.</li> </ol>	<p>See Page 11 See Page 6</p>
<b>The cloth is not feeding smoothly.</b>	<ol style="list-style-type: none"> <li>1. The feed dog is packed with lint.</li> <li>2. The stitches are too fine.</li> </ol>	<p>See Page 29 Make the stitches coarser.</p>
<b>The machine does not work.</b>	<ol style="list-style-type: none"> <li>1. The machine is not plugged in.</li> <li>2. Thread is caught in the hook race.</li> </ol>	<p>See Page 4 See Page 29</p>
<b>The machine does not run smoothly and is noisy.</b>	<ol style="list-style-type: none"> <li>1. Threads have been caught in hook mechanism.</li> <li>2. The feed dog is packed with lint.</li> </ol>	<p>See page 29 See Page 29</p>

