



View this machine and more at:

<https://www.thesewingstudio.co.uk>

brother

Operation Manual

Cover stitch machine / Top cover stitch machine

Product Code: 884-B30 / B31

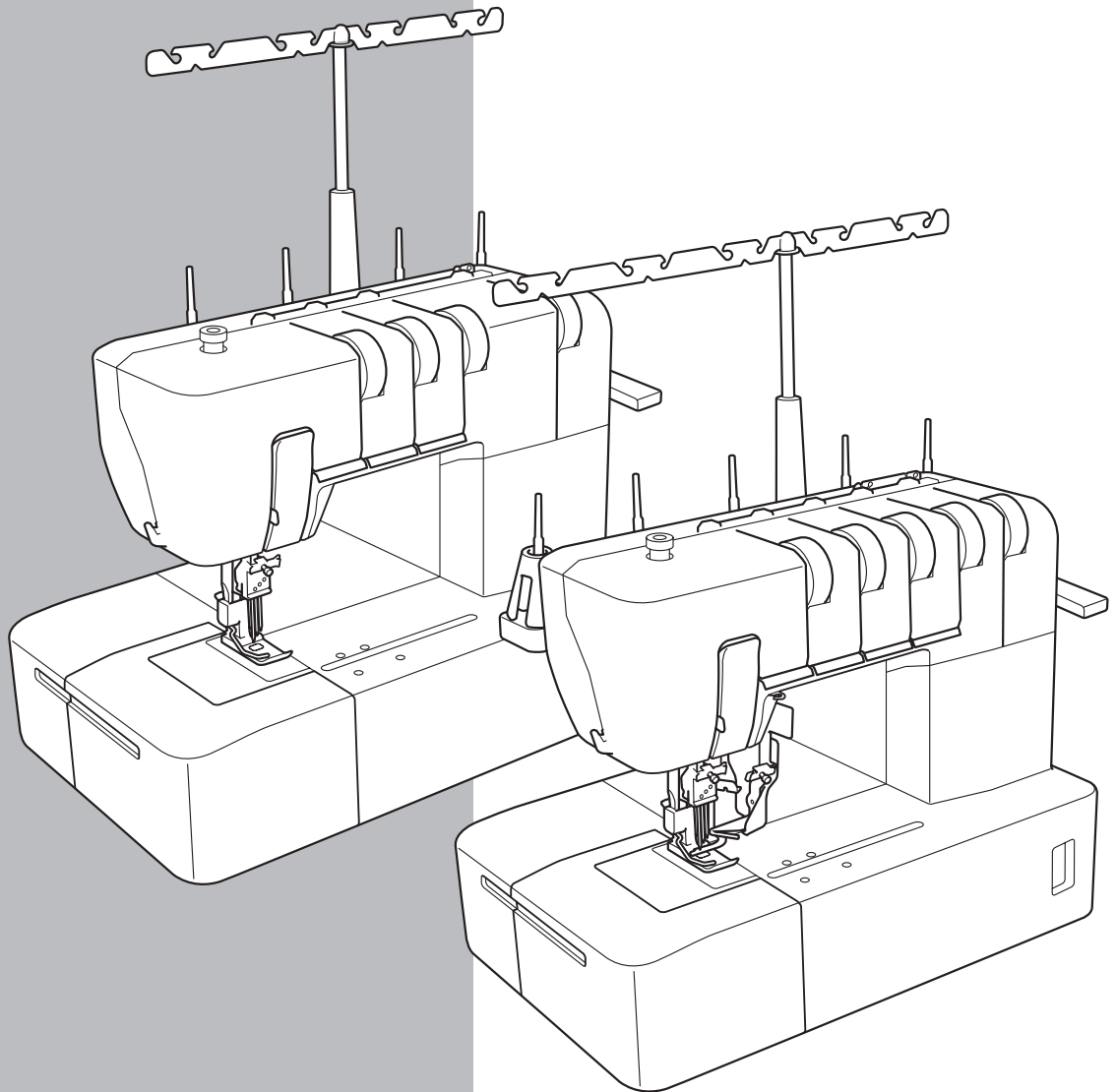

Be sure to read this document before using the machine.
We recommend that you keep this document nearby for future reference.

IMPORTANT SAFETY INSTRUCTIONS

When using the sewing machine, basic safety precautions should always be followed, including the following. Read all instructions before using this machine.

DANGER

To reduce the risk of electric shock.

The sewing machine should never be left unattended when plugged in. Always unplug this sewing machine from the electrical outlet immediately after using and before cleaning.

WARNING

To reduce the risk of burns, fire, electric shock, or injury to persons.

1. Do not allow to be used as a toy. Close attention is necessary when the sewing machine is used by or near children.
2. Use this sewing machine only for its intended use as described in this manual. Use only accessories recommended by the manufacturer as contained in this manual.
3. Never operate this sewing machine if it has a damaged cord or plug, if it is not working properly, if it has been dropped or damaged, or dropped into water. Return the sewing machine to the nearest authorized dealer or service center for examination, repair, electrical or mechanical adjustment.
4. Never operate the sewing machine with any air openings blocked. Keep ventilation openings of the sewing machine and foot controller free from the accumulation of lint, dust, and loose cloth.
5. Never drop or insert any object into any openings.
6. Do not use outdoors.
7. Do not operate where aerosol (spray) products are being used or where oxygen is being administered.
8. To disconnect, turn the main switch to the symbol "O" position which represents off, then remove plug from outlet.
9. Do not unplug by pulling on cord. To unplug, grasp the plug, not the cord.
10. Keep fingers away from all moving parts. Special care is required around the sewing machine needle.
11. Always use the proper needle plate. The wrong plate can cause the needle to break.
12. Do not use bent needles.
13. Do not pull or push fabric while stitching. It may deflect the needle causing it to break.
14. Switch the sewing machine to the symbol "O" position when making any adjustments in the needle area, such as threading needle, changing needle, or changing presser foot, etc.
15. Always unplug the sewing machine from the electrical outlet when removing covers, lubricating, or when making any other user servicing adjustments mentioned in the instruction manual.
16. Electrical Hazards:
 - This machine should be connected to an AC power source within the range indicated on the rating label. Do not connect it to a DC power source or inverter. If you are not sure what kind of power source you have, contact a qualified electrician.

- This machine is approved for use in the country of purchase only.
17. This sewing machine is not intended for use by young children or infirm persons without supervision.
 18. Young children should be supervised to ensure that they do not play with this sewing machine.
 19. Do not disassemble the machine.
 20. If the LED light unit (light-emitting diode) is damaged, it must be replaced by authorized dealer.

CAUTION

To use the machine safely

1. (For U.S.A. only)
 - This appliance has a polarized plug (one blade wider than the other) to reduce the risk of electric shock, this plug is intended to fit in a polarized outlet only one way. If the plug does not fit fully in the outlet, reverse the plug. If it still does not fit, contact a qualified electrician to install the proper outlet.
 - Do not modify the plug in any way.
2. Make sure you watch the needles carefully while you are sewing. Do not touch the handwheel, needles, knives, or other moving parts.
3. Turn off the main power and unplug the cord in the following circumstances:
 - When you have stopped using the machine
 - When you are replacing or removing the needle or any other part
 - If there is a power failure while you are using the machine
 - If you are checking or cleaning the machine
 - Leaving the machine unattended
4. Do not store anything on the foot controller.
5. Fully plug the machine directly into the wall. Do not use extension cords.
6. If water is dropped on the machine, unplug the machine immediately, and contact your local authorized dealer.
7. Do not put furniture on the cord.
8. Do not bend the cord, or pull on the cord to unplug.
9. Do not touch the cord with wet hands.
10. Place the machine near to the wall outlet.
11. Do not place the machine on an unstable surface.
12. Do not put on the soft cover.
13. If you notice any abnormal sound or condition, consult your local authorized dealer.

To give your machine a longer life

1. Do not store this machine in direct sunlight or in high humidity conditions. Do not use or store the machine near a heater, iron, halogen lamp or other hot object.
2. Use only mild soaps or detergents to clean the case. Benzene, thinner, and scouring powders can damage the case and machine, and should never be used.
3. Do not drop or hit the machine.
4. Always consult this manual before you replace or fit the presser foot, needle, or any other parts to make sure you fit them correctly.

To repair or adjust the machine

If the machine breaks down or needs adjustment, first follow the troubleshooting table to inspect and adjust the machine yourself. If the problem persists, consult your local authorized dealer.

SAVE THESE INSTRUCTIONS

This machine is intended for household use.

FOR USERS IN COUNTRIES EXCEPT CENELEC COUNTRIES

This appliance is not intended for use by persons (including children) with reduced physical, sensory or mental capabilities, or lack of experience and knowledge, unless they have been given supervision or instruction concerning use of the appliance by a person responsible for their safety. Children should be supervised to ensure that they do not play with the appliance.

FOR USERS IN CENELEC COUNTRIES

This appliance can be used by children aged from 8 years and above and persons with reduced physical, sensory or mental capabilities or lack of experience and knowledge if they have been given supervision or instruction concerning use of the appliance in a safe way and understand the hazards involved. Children shall not play with the appliance. Cleaning and user maintenance shall not be made by children without supervision.

! CAUTION

When leaving this sewing machine unattended, the main power and light switch of the machine must be switched off or the plug must be removed from the socket-outlet.

When servicing the sewing machine, or when removing covers, the machine or the electrical set must be disconnected from the supply by removing the plug from the socket-outlet.

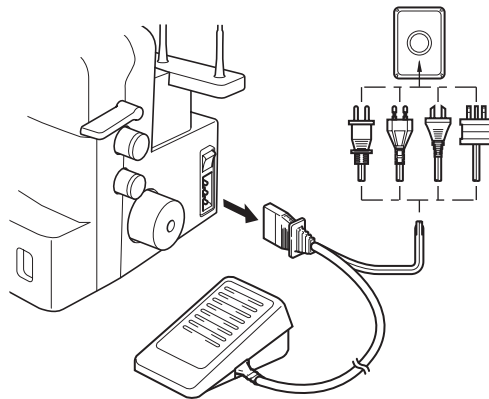

FOR USERS IN THE UK, EIRE, MALTA AND CYPRUS ONLY

IMPORTANT

- In the event of replacing the plug fuse, use a fuse approved by ASTA to BS 1362, i.e. carrying the  mark, rating as marked on plug.
- Always replace the fuse cover. Never use plugs with the fuse cover omitted.
- If the available electrical outlet is not suitable for the plug supplied with this equipment, you should contact your authorized dealer to obtain the correct lead.

CONGRATULATIONS ON CHOOSING THIS COMPACT OVERLOCK MACHINE

Your machine is a high quality, easy-to-use product. To fully enjoy all the features, we suggest that you study this booklet.

If you need more information regarding the use of your machine, your nearest authorized dealer is always happy to be of service.

Enjoy yourself!

⚠ CAUTION

When threading or replacing needle, the main power and light switch of the machine must be switched off or the plug must be removed from the socket-outlet.

When the machine is not in use, it is recommended that the electric supply plug is disconnected from the wall socket to avoid any possible hazards.

Notes on the motor

- The maximum operating speed of this sewing machine is 1,000 stitches per minute, which is quite fast compared to the normal operating speed of 300 to 800 stitches per minute for the ordinary sewing machine.
- The bearings in the motor are made of a special material (oil-impregnated alloy mounted in felt heat-treated with oil) that enables them to withstand long hours of continuous operation.
- Continuous operation of the sewing machine can cause heat to build in the motor area, but not enough to adversely affect its performance.
It is important to keep fabric and paper away from the air openings on the back and sides of the machine so air can get to these openings.
- When the motor is running, sparks can be seen through the air openings in the motor bracket on the side opposite the handwheel. These sparks are produced by the carbon brushes and the commutator, and are part of the machines normal operation.

WARNING LABELS (for complying with UL and CSA requirements)

The following warning labels are on the machine.

Be sure to observe the precautions described in the labels.

Caution (U.S.A. and CANADA only)

① **CAUTION:**
MOVING PARTS- TO AVOID INJURY:
CLOSE COVER BEFORE SEWING.
UNPLUG BEFORE SERVICING.

② **AVERTISSEMENT:**
PARTIES EN MOUVEMENT. POUR
ÉVITER TOUTE BLESSURE:
FERMER LE CAPOT AVANT DE
COUDRE.
DÉBRANCHER AVANT ENTRETIEN.

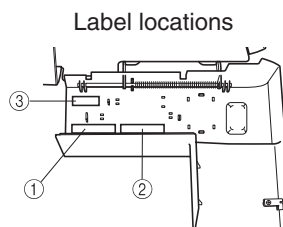

Face plate sticker (U.S.A. and CANADA only)

③ **CLOSE DOOR BEFORE
OPERATING MACHINE**
FERMER LE COUVERT AVANT
D'OPÉRER LA MACHINE

Contents

Chapter 1 : NAMES OF PARTS AND THEIR FUNCTIONS	4
Machine (Cover stitch model) (Product code: 884-B30)	4
Accessories (Cover stitch model)	5
Machine (Top cover stitch model) (Product code: 884-B31)	6
Accessories (Top cover stitch model)	7
Powering the machine.....	8
Turning direction of handwheel.....	8
Opening/Closing front cover	8
Attaching/Removing a presser foot.....	8
Free-arm sewing (removing the bed extension).....	9
Looper thread tension adjustment lever.....	9
Stitch length	10
Differential feed	10
Adjusting the presser foot pressure	11
Adjusting the tension dials	11
Needle	12
Removing/Installing the needle.....	12
Chapter 2 : PREPARATION BEFORE THREADING	13
Thread tree	13
Using the thread spool cap	13
Spool mat.....	13
Using the spool mat	13
Using the thread net	14
Before threading	14
Chapter 3 : THREADING (Cover stitch model)	15
Threading the looper.....	15
Threading the needles	16
Chapter 4 : THREADING (Top cover stitch model)	17
Threading the looper.....	17
Threading the needles	18
Attaching/Removing the top cover spreader and top cover thread guide	19
Threading the top cover spreader.....	20
Chapter 5 : TYPE OF STITCHES COMPARISON CHART	21
Chapter 6 : SEWING	24
Sewing flat fabric (for example, trial sewing).....	24
Removing the fabric from the machine (Cover stitch model)	24
Removing the fabric from the machine (Top cover stitch model)	25
Sewing a cover stitch	27
Sewing tubular garments (for example, cuffs).....	27
Stabilizing the beginning and end of stitching.....	28
Chapter 7 : TROUBLESHOOTING	29
Chapter 8 : MAINTENANCE	30
Cleaning.....	30
SPECIFICATIONS	31

CHAPTER 1 NAMES OF PARTS AND THEIR FUNCTIONS

Machine (Cover stitch model) (Product code: 884-B30)

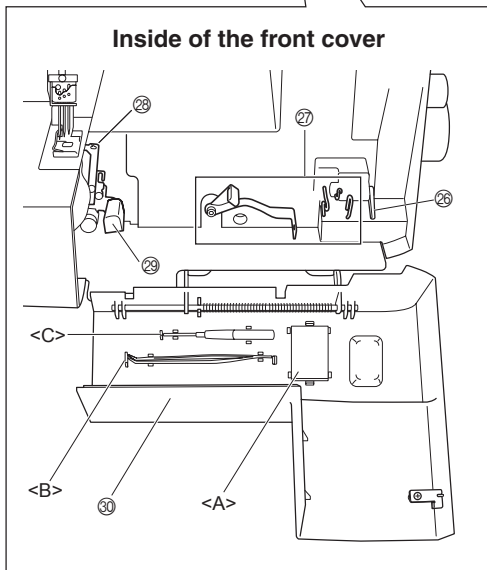
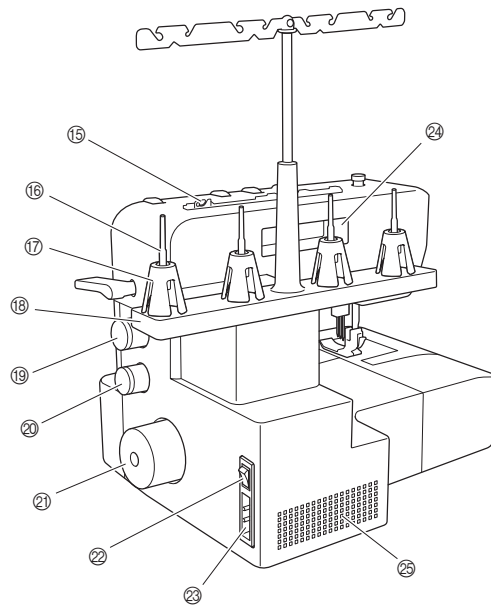
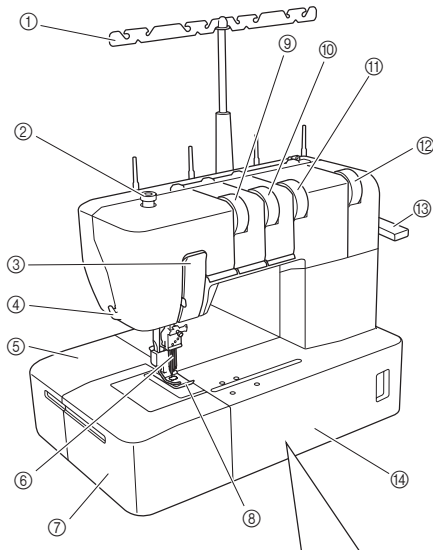

- ① Thread tree
- ② Presser foot pressure adjustment screw
- ③ Thread take-up cover
- ④ Thread cutter
- ⑤ Material plate cover
- ⑥ Needles
- ⑦ Bed extension
- ⑧ Presser foot
- ⑨ Left needle thread tension dial
- ⑩ Center needle thread tension dial
- ⑪ Right needle thread tension dial
- ⑫ Looper thread tension dial
- ⑬ Presser foot lever
- ⑭ Front cover
- ⑮ Thread guide
- ⑯ Spool pin
- ⑰ Spool cushion

- ⑱ Spool support
- ⑲ Stitch length adjustment dial
- ⑳ Differential feed ratio adjustment dial
- ㉑ Handwheel
- ㉒ Main power and light switch
- ㉓ Foot controller socket
- ㉔ Handle
- ㉕ Air openings

Inside of the front cover

- ㉖ Looper thread tension adjustment lever
- ㉗ Looper thread take-up
- ㉘ Looper
- ㉙ Looper release lever
- ㉚ Front cover compartment

You can store the included accessories in this front cover compartment. <A>: Needle set, : Tweezers, <C>: Hexagonal driver

Accessories (Cover stitch model)

■ Included accessory

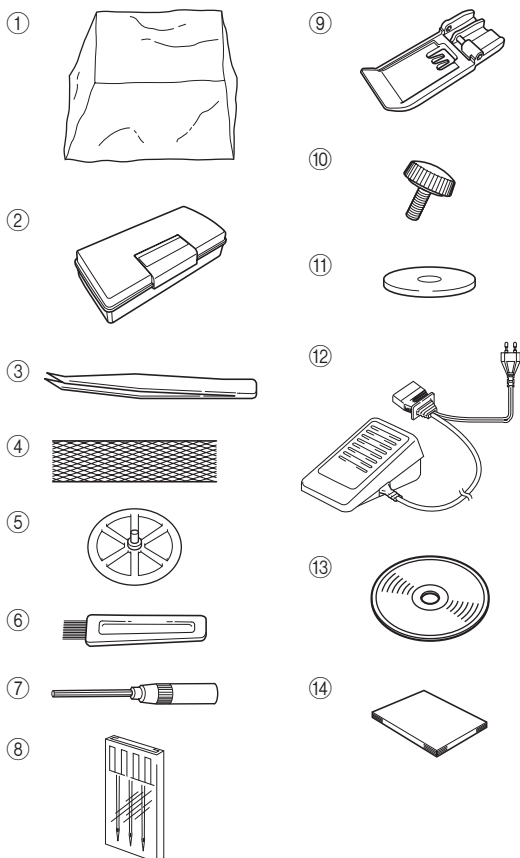

No.	Part Name	Part Code
①	Soft cover	XB3264001
②	Accessory box	XB3291001
③	Tweezers	XB1618001
④	Thread net (4)	X75904000
⑤	Thread spool cap (4)	X77260000
⑥	Cleaning brush	X75906001
⑦	Hexagonal driver	XB0393001
⑧	Needle set (130/705H) #90: 3 pcs.	XB1216001
⑨	Clear foot	XB3361001
⑩	Attachment screw (2)	XB3292001
⑪	Spool mat (4)	XB1218001
⑫	Foot controller	XC7359021 (120V Area) XB3112001 (230V Area) XB3134001 (U.K.) XB3200001 (Argentina) XB3156001 (Korea) XB3255001 (China) XB3190001 (Australia, New Zealand) XF2826001 (Brazil 127V) XB3178001 (Brazil 220V)
⑬	Instruction DVD	XB3301001 (NTSC) XB3305001 (PAL)
⑭	Operation Manual	-

■ Optional accessory

When using the following accessories, use the presser foot included in the accessories.

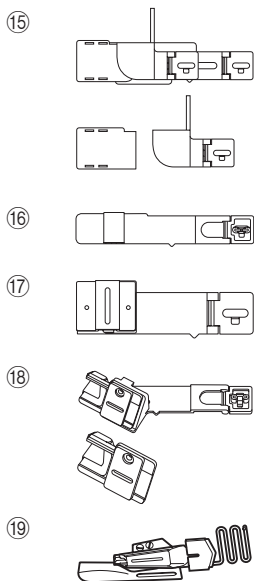

No.	Product Name	Part Code		
		Americas	Europe	Others
⑮	Hemming set	SA221CV	SA221CV/ XB2970-101	SA221CV
⑯	Bias tape folder	SA222CV	SA222CV/ XB2971-101	SA222CV
⑰	Belt loop guide	SA223CV	SA223CV/ XB2972-101	SA223CV
⑱	Bias tape binding set	SA230CV	SA230CV/ XB3387-001	-
⑲	Dual function fold binder	SA231CV	SA231CV/ XB3388-001	SA231CV

Machine (Top cover stitch model) (Product code: 884-B31)

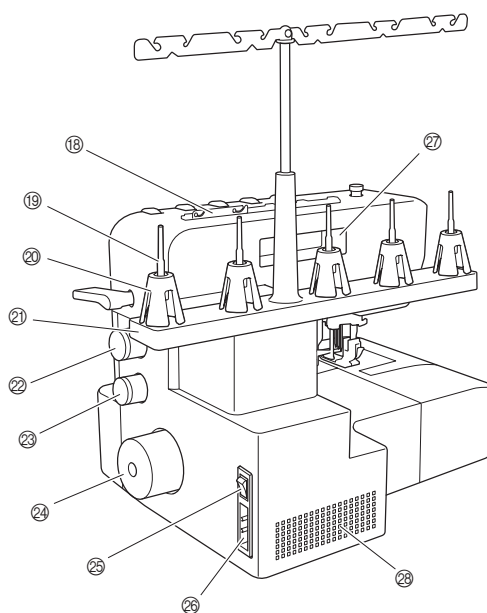
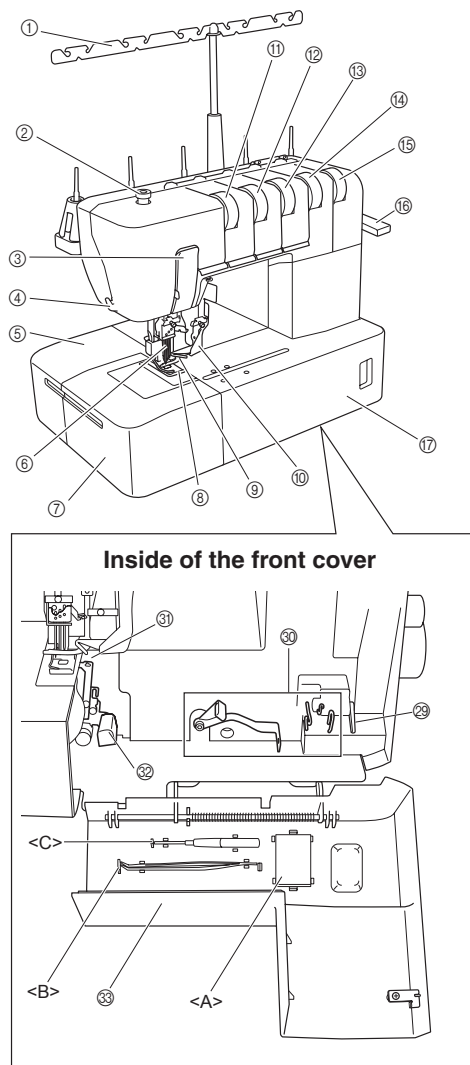

- ① Thread tree
- ② Presser foot pressure adjustment screw
- ③ Thread take-up cover
- ④ Thread cutter
- ⑤ Material plate cover
- ⑥ Needles
- ⑦ Bed extension
- ⑧ Presser foot
- ⑨ Top cover spreader
- ⑩ Top cover thread guide
- ⑪ Left needle thread tension dial
- ⑫ Center needle thread tension dial
- ⑬ Right needle thread tension dial
- ⑭ Top cover thread tension dial
- ⑮ Looper thread tension dial
- ⑯ Presser foot lever
- ⑰ Front cover
- ⑱ Thread guide
- ⑲ Spool pin

- ⑳ Spool cushion
- ㉑ Spool support
- ㉒ Stitch length adjustment dial
- ㉓ Differential feed ratio adjustment dial
- ㉔ Handwheel
- ㉕ Main power and light switch
- ㉖ Foot controller socket
- ㉗ Handle
- ㉘ Air openings

Inside of the front cover

- ㉙ Looper thread tension adjustment lever
- ㉚ Looper thread take-up
- ㉛ Looper
- ㉜ Looper release lever
- ㉝ Front cover compartment

You can store the included accessories in this front cover compartment. <A>: Needle set, : Tweezers, <C>: Hexagonal driver

Accessories (Top cover stitch model)

■ Included accessory

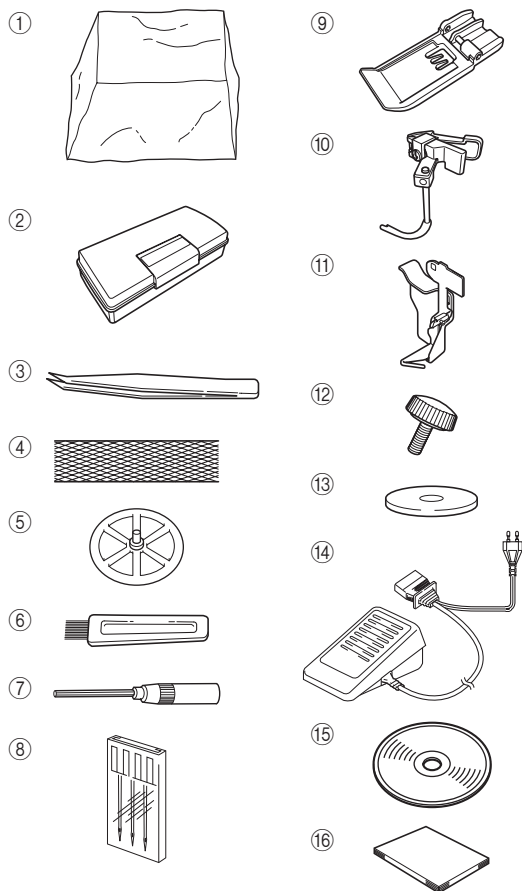

No.	Part Name	Part Code
①	Soft cover	XB3264001
②	Accessory box	XB3291001
③	Tweezers	XB1618001
④	Thread net (5)	X75904000
⑤	Thread spool cap (5)	X77260000
⑥	Cleaning brush	X75906001
⑦	Hexagonal driver	XB0393001
⑧	Needle set (130/705H) #90: 3 pcs.	XB1216001
⑨	Clear foot	XB3361001
⑩	Top cover spreader	XB3090001
⑪	Top cover thread guide	XB3105001
⑫	Attachment screw (2)	XB3292001
⑬	Spool mat (5)	XB1218001
⑭	Foot controller	XC7359021 (120V Area) XB3112001 (230V Area) XB3134001 (U.K.) XB3200001 (Argentina) XB3156001 (Korea) XB3255001 (China) XB3190001 (Australia, New Zealand) XF2826001 (Brazil 127V) XB3178001 (Brazil 220V)
⑮	Instruction DVD	XB3301001 (NTSC) XB3305001 (PAL)
⑯	Operation Manual	-

■ Optional accessory

When using the following accessories, use the presser foot included in the accessories.

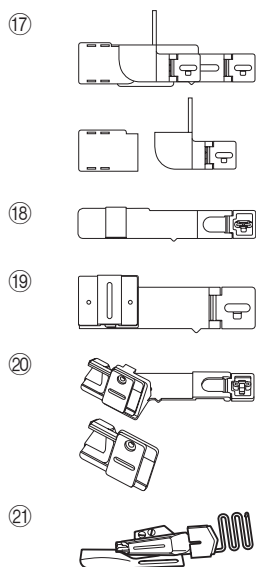

No.	Product Name	Part Code		
		Americas	Europe	Others
⑰	Hemming set *	SA221CV	SA221CV/ XB2970-101	SA221CV
⑱	Bias tape folder	SA222CV	SA222CV/ XB2971-101	SA222CV
⑲	Belt loop guide	SA223CV	SA223CV/ XB2972-101	SA223CV
⑳	Bias tape binding set	SA230CV	SA230CV/ XB3387-001	-
㉑	Dual function fold binder	SA231CV	SA231CV/ XB3388-001	SA231CV

* Can be used only with a cover stitch; cannot be used with a top cover stitch.

Powering the machine

■ Turning on the machine

1. Insert the three-pin plug into the socket on the lower-right side of the machine. Insert the power supply plug into a power outlet.
2. Turn the main power and light switch <A> to "I" mark (to "O" mark to turn off).

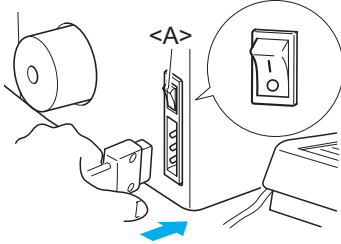

■ Operation

When the foot controller is pressed lightly, the machine runs at a low speed. As the foot controller is pressed further, the machine will increase speed. When the foot controller is released, the machine stops.

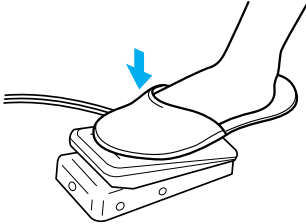

NOTE (For U.S.A. only):

Foot controller: Model KD-1902

This foot controller can be used on the machine with product code 884-B30 and 884-B31.

** The product code is shown on the machine rating plate.*

Turning direction of handwheel

The handwheel <A> turns in a counterclockwise direction (direction of arrow). This is the same direction as an ordinary home sewing machine. Move the needles to their highest positions by turning the handwheel so that the mark on the handwheel is aligned with the line on the machine.

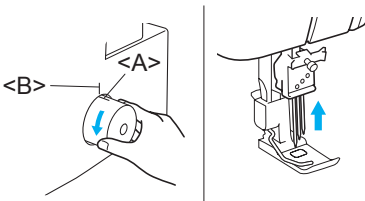

Opening/Closing front cover

It is necessary to open the front cover when threading this machine. Slide it to the right ①, and then open it ②. After closing it, slide it to the left.

⚠ CAUTION

For your safety, make sure that the front cover is closed when operating the machine.

Always turn off the machine before opening the front cover.

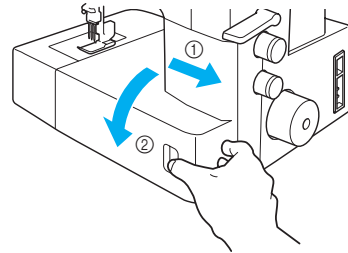

Attaching/Removing a presser foot

1. Turn off the main power and light switch or disconnect the power supply plug.
2. Raise the presser foot lever ①.
3. Turn the handwheel ② so that the line on the handwheel is aligned with the line on the machine. (See "Turning direction of handwheel" in CHAPTER 1.)
4. Push the button on the presser foot holder ③ to release the standard presser foot.
5. Raise the presser foot farther by pushing the presser foot lever upward. Then, remove the presser foot and store it in a safe location.
6. Again, raise the presser foot farther by pushing the presser foot lever upward. Place the presser foot just under the presser foot holder <A> so that the groove in the bottom of the presser foot holder is aligned with the bar on the top of the foot <C>, and then lower the presser foot lever to attach the foot ④.

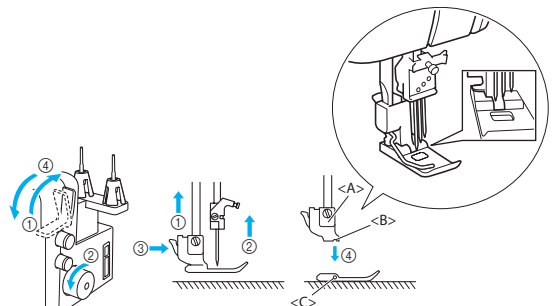

Free-arm sewing (removing the bed extension)

Free-arm sewing enables tubular pieces to be sewn more easily.

1. Remove the bed extension.

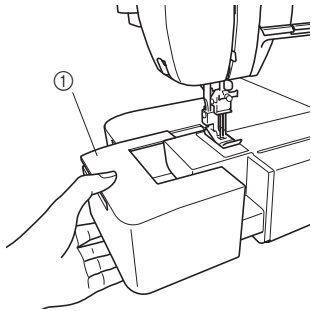

- ① Bed extension

NOTE:

Be careful not to lose the removed bed extension.

2. Position the fabric, and then start sewing.
(See CHAPTER 5.)

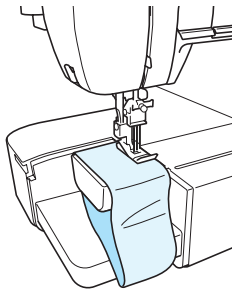

Looper thread tension adjustment lever

With the looper thread tension adjustment lever, fine adjustments can be made to the looper thread tension. When sewing stretch fabric or with a small stitch length, raise the lever to increase the tension of the looper thread. When sewing non-stretch fabric or with a large stitch length, lower the lever to reduce the tension of the looper thread.

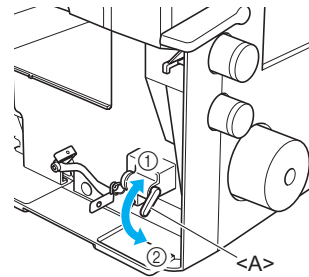

- ① Raise the lever to increase the tension of the looper thread.
 - ② Lower the lever to reduce the tension of the looper thread.
- <A> Looper thread tension adjustment lever

■ Non-stretch fabric such as serge

Reduce the tension of the looper thread.

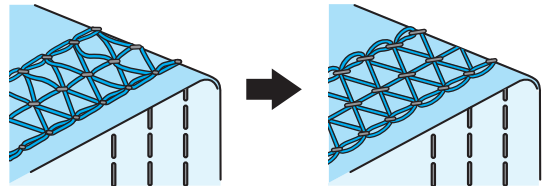

Lever position: Center

Lever position: Down

■ Stretch fabric such as smooth knit

Increase the tension of the looper thread.

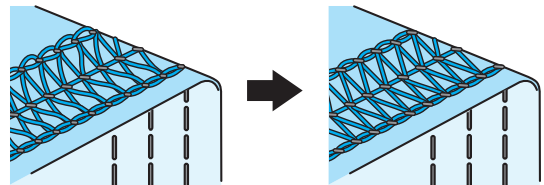

Lever position: Center

Lever position: Up

Stitch length

The normal stitch length setting is 3 mm. To change the stitch length, turn the stitch length adjustment dial on the right side of the machine.

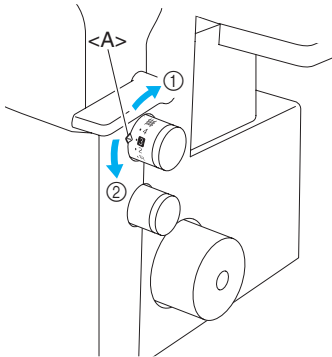







- ① Shorten the stitch length to a minimum of 2 mm (5/64 inch).
 - ② Lengthen the stitch to a maximum of 4 mm (5/32 inch).
- <A> Selection mark

Differential feed

There are two sets of feed dogs under the presser foot to move the fabric through the machine. The differential feed controls the movement of both the front and the rear feed dogs. When set at 1, the feed dogs are moving at the same speed (ratio of 1). When the differential feed ratio is set at less than 1, the front feed dogs move less than the rear feed dogs, stretching the fabric as it is sewn. This is effective on lightweight fabric that may pucker. When the differential feed ratio is set at greater than 1, the front feed dogs move more than the rear feed dogs, gathering the fabric as it is sewn. This function assists in removing rippling when sewing stretch fabrics.

■ Differential feed adjustment

Feed ratio	Main feed (rear)	Differential feed (front)	Effect	Application
Less than 1.0			Material is pulled tight.	Prevents thin materials from puckering
1.0			Without differential feed.	Normal sewing
Greater than 1.0			Material is gathered or pushed together.	Prevents stretch materials from stretching or puckering

The normal setting is 1.0 on the differential feed adjustment dial.

To adjust the differential feed, turn the dial on the lower-right side of the machine.

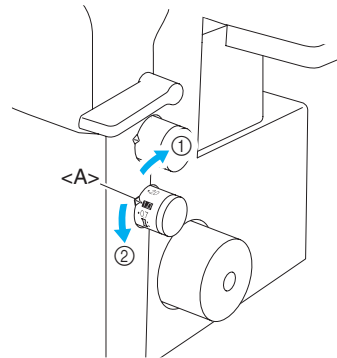

- ① Less than 1.0
 - ② Greater than 1.0
- <A> Selection mark

An example

When stretch material is sewn without using the differential feed, the fabric will be wavy.

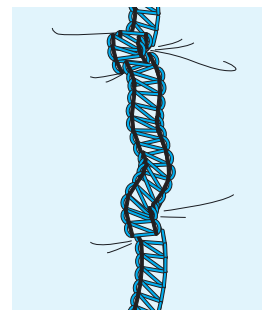

To get a smooth finish, adjust the feed ratio from 1.0 toward 2.0.

(The feed ratio required depends on the elasticity of the material.)

The more elastic the material, the further toward 2.0 the differential feed ratio should be set. Test sew with a scrap of the fabric to find the correct adjustment.

! CAUTION

When sewing thick non-stretchable material such as denim, do not use the differential feed as it may damage the fabric.

Adjusting the presser foot pressure

Turn the pressure adjustment screw on the left of the top of the machine. Refer to the value on the screw to make the adjustment.

The normal setting is "2".

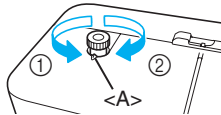

- ① Less pressure
- ② More pressure
- <A> Selection mark

Adjusting the tension dials

There is a thread tension dial for each needle thread, the looper thread and the top cover thread. The correct thread tension may vary according to the type and thickness of the fabric and the type of thread used. Thread tension adjustments may be necessary for any change in sewing materials.

■ Cover stitch model

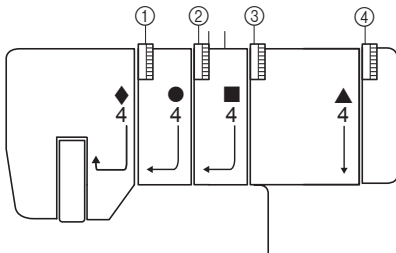

- ① The tension dial marked in yellow is for the left needle thread.
- ② The tension dial marked in green is for the center needle thread.
- ③ The tension dial marked in pink is for the right needle thread.
- ④ The tension dial marked in blue is for the looper thread.

■ Top cover stitch model

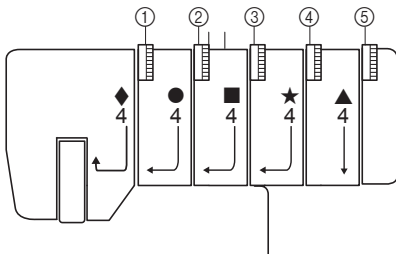

- ① The tension dial marked in yellow is for the left needle thread.
- ② The tension dial marked in green is for the center needle thread.
- ③ The tension dial marked in pink is for the right needle thread.
- ④ The tension dial marked in purple is for the top cover thread.
- ⑤ The tension dial marked in blue is for the looper thread.

■ Tension control

Sewing is possible at position "4" for most circumstances. (Standard: SPAN #60)

If the stitch quality is insufficient, select a different tension setting.

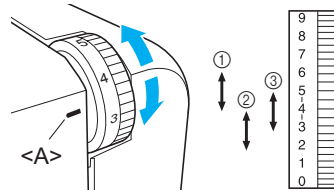

- ① For heavy tension: 4 to 6
- ② For light tension: 4 to 2
- ③ For medium tension: 5 to 3
- <A> Tension selection mark

⚠ CAUTION

Make sure that the thread is properly seated in the tension discs.

Needle

This machine uses a standard home sewing machine needle.

The recommended needle is 130/705H (#90).

Needle description

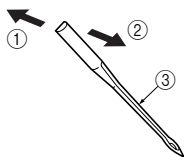

- ① Back (flat side)
- ② Front
- ③ Groove

How to check the needle

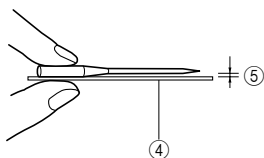

- ④ Flat surface
- ⑤ Place the needle on its flat side and check to see if the space is even.

NOTE:

Fabric damage can be reduced by using 130/705H SUK (#90) BALL POINT.

Removing/Installing the needle

- <A> Removing/installing the left needle
- Removing/installing the center needle
- <C> Removing/installing the right needle

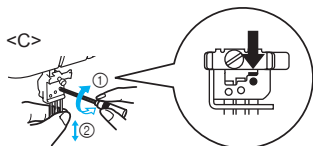
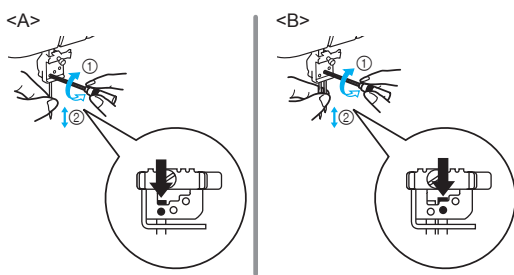

- ① Tighten
- ② Loosen

To remove:

1. Turn off the main power and light switch.
2. Turn the handwheel so that the line on the handwheel is aligned with the line on the machine. (See "Turning direction of handwheel" in CHAPTER 1.)
3. Loosen the corresponding needle set screw by turning it with the included hexagonal driver toward ② in the illustration, and then remove the needle.

To install:

1. Turn off the main power and light switch.
2. Turn the handwheel so that the line on the handwheel is aligned with the line on the machine.
3. Hold the needle with its flat side away from you and insert it up as far as it will go.
4. Tighten the needle set screw securely by turning it with turning the included hexagonal driver toward ① in the illustration.

NOTE:

Be sure to insert the needles all the way.

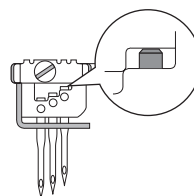

CAUTION

Always be sure to turn off the power before removing/inserting the needle.

Do not drop the needle and needle set screw in the machine, otherwise it may be damaged.

CHAPTER 2

PREPARATION BEFORE THREADING

Thread tree

Raise the telescoping thread tree to its highest position. Make sure that the thread holders are in alignment above the spool pins as illustrated below.

Cover stitch model

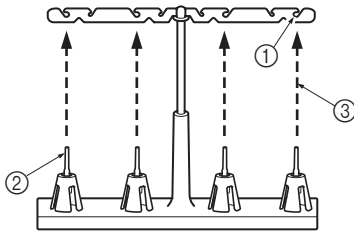

Top cover stitch model

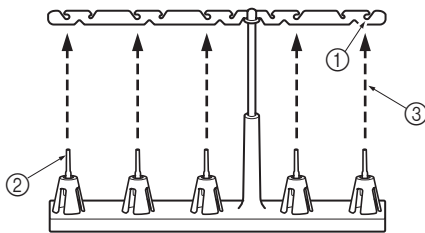

- ① Thread holder on thread tree
- ② Spool pin
- ③ Correct position

Using the thread spool cap

When using sewing thread spools, the thread spool cap should be used as illustrated below. Make sure that the spool notch is on the bottom.

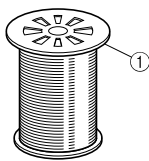

- ① Thread spool cap

CAUTION

Before using a thread spool, be sure to remove the spool cushion.

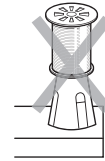

Before using loosely spun nylon thread, be sure to install the spool cushion.

If the thread spool cap is not fully pushed down, the thread may become entangled on the spool pin or the needle may bend or break.

Spool mat

When using thread spools or loosely spun thread that easily slips off the spool, place this mat under the spool.

This prevents the thread from becoming entangled on the spool pin.



Using the spool mat

1. Remove the spool cushion, and then place the spool mat on the spool pin.
2. Place the thread spool (with the spool notch at the bottom) on the spool pin, and then place the thread spool cap on top and fully push it down.

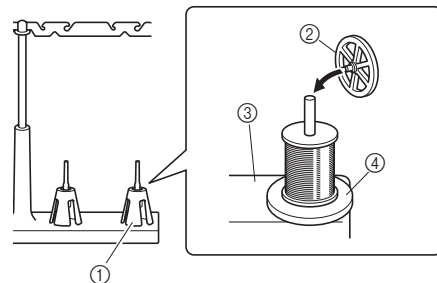

- ① Spool cushion
- ② Thread spool cap
- ③ Spool support
- ④ Spool mat

CAUTION

If the thread spool cap is not fully pushed down against the thread spool, the thread may become entangled on the spool pin or the needle may bend or break.

Using the thread net

If you are sewing with loosely spun nylon thread, we recommend that you cover the spool with the included net in order to prevent the thread from slipping off the spool.

Adapt the net to the shape of the spool.

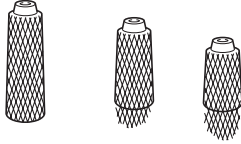

Before threading

1. Turn off the main power and light switch for safety.

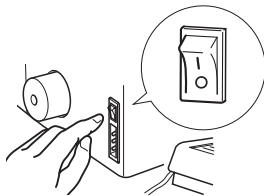

2. Raise the presser foot using the presser foot lever.

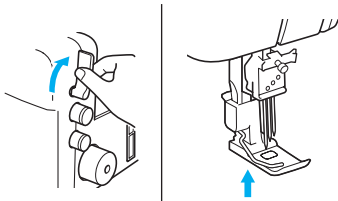

3. Turn the handwheel so that the line on the handwheel <A> is aligned with the line on the machine. (See “Turning direction of handwheel” in CHAPTER 1.)

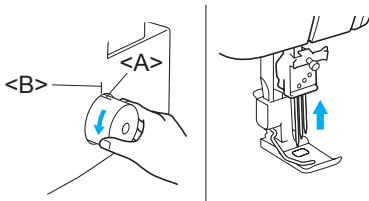

CHAPTER 3 THREADING (Cover stitch model)

⚠ CAUTION

Before threading, turn off the machine for safety.

Threading the looper

Run the thread in the sequence illustrated, following the blue line and the numbers next to each threading point.

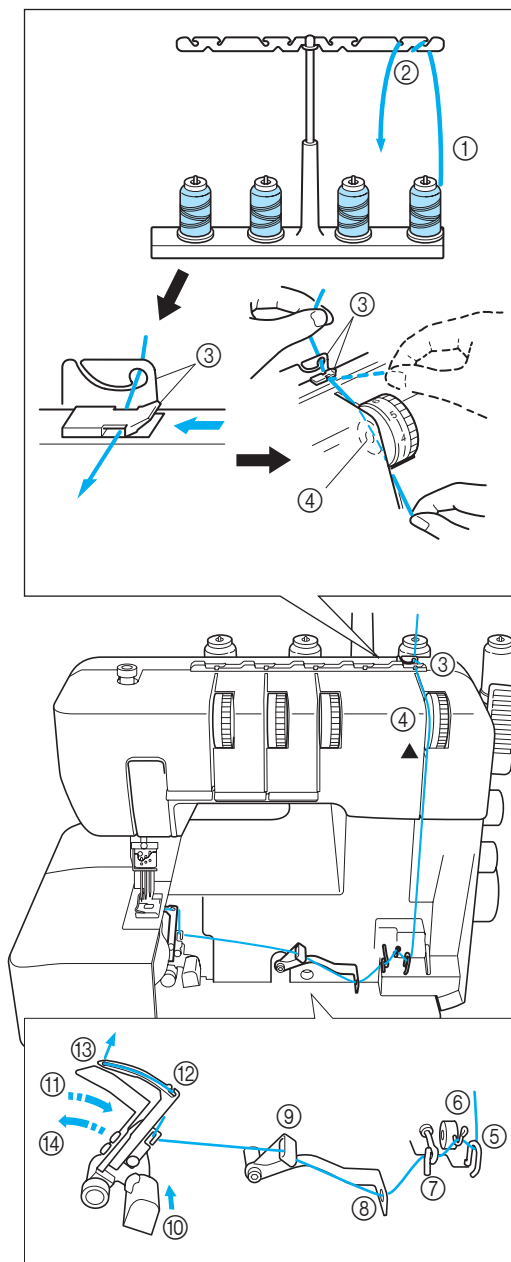

1. Open the front cover by sliding it to the right and guiding the top toward you.
2. Pull the thread off the spool and directly up through thread holder ① and thread holder ② on the thread tree, from back to front.
3. Pass the looper thread ③ as shown in the illustration.
4. Pass the thread through the tension disc ④ in the channel next to the tension dial marked with a blue ▲.
5. Guide the thread down the channel and through threading points ⑤-⑨, following the numerical order in the illustration.
6. After running the thread to ⑨, push the looper release lever ⑩ to move the looper to the right ⑪, and then run the thread through ⑫-⑬.
7. Pull about 10 cm (4 inch) of thread through the eye of the looper.
8. While pushing the looper ⑭, return the looper to its original position.
9. Close the front cover.

NOTE:

When using thick thread, such as decorative thread, as the looper thread, run the thread as shown in the illustration.

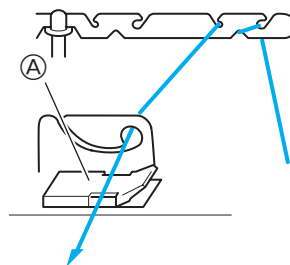

Do not run the thread through ①.

Threading the needles

■ Needle threads used by the various stitches

The triple cover stitch (three-needle, four-thread cover stitch) uses the left needle thread, center needle thread and right needle thread.

The two-needle, three-thread cover stitch (Wide) (6 mm (15/64 inch)) uses the left needle thread and right needle thread.

The two-needle, three-thread cover stitch (Narrow) (3 mm (1/8 inch)) uses the center needle thread and right needle thread.

The chain stitch uses the center needle thread and looper thread.

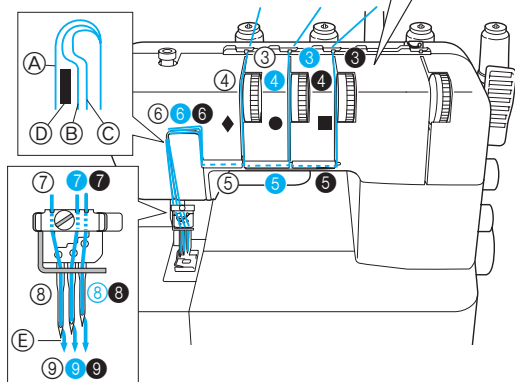
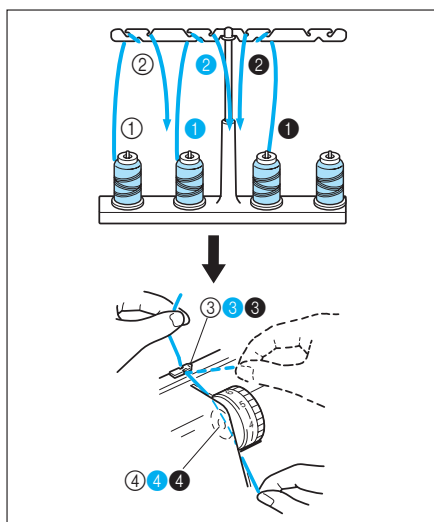

- (A) To left needle
- (B) To center needle
- (C) To right needle
- (D) Branching plate
- (E) Pull about 6 cm (about 2-1/2 inches) of thread through the eye of the needle.
- (9) (9) (9) Front to back

Threading the left needle

Run the thread in the sequence illustrated, following the yellow numbers and ◆ marks next to the threading points. (①-⑨)

Threading the center needle

Run the thread in the sequence illustrated, following the green numbers and ● marks next to the threading points. (①-⑨)

Threading the right needle

Run the thread in the sequence illustrated, following the pink numbers and ■ marks next to the threading points. (①-⑨)

⚠ CAUTION

When threading the needles, always thread in the following order: left needle, center needle and right needle.

1. Pull the thread off the spool and directly up through thread holder ① ① ① and thread holder ② ② ② on the thread tree, from back to front.
2. Pass each thread through ③ ③ ③, shown in the illustration.
3. Pass the thread through the tension disc ④ ④ ④ in the channel next to the tension dial.
4. Guide the thread down the channel and across through threading points ⑤ ⑤ ⑤-⑧ ⑧ ⑧ next to the color marks, following the numerical order in the illustration.
5. Pass the thread through the eye of the needle, front to back.

CHAPTER 4

THREADING (Top cover stitch model)

⚠ CAUTION

Before threading, turn off the machine for safety.

Threading the looper

Run the thread in the sequence illustrated, following the blue line and the numbers next to each threading point.

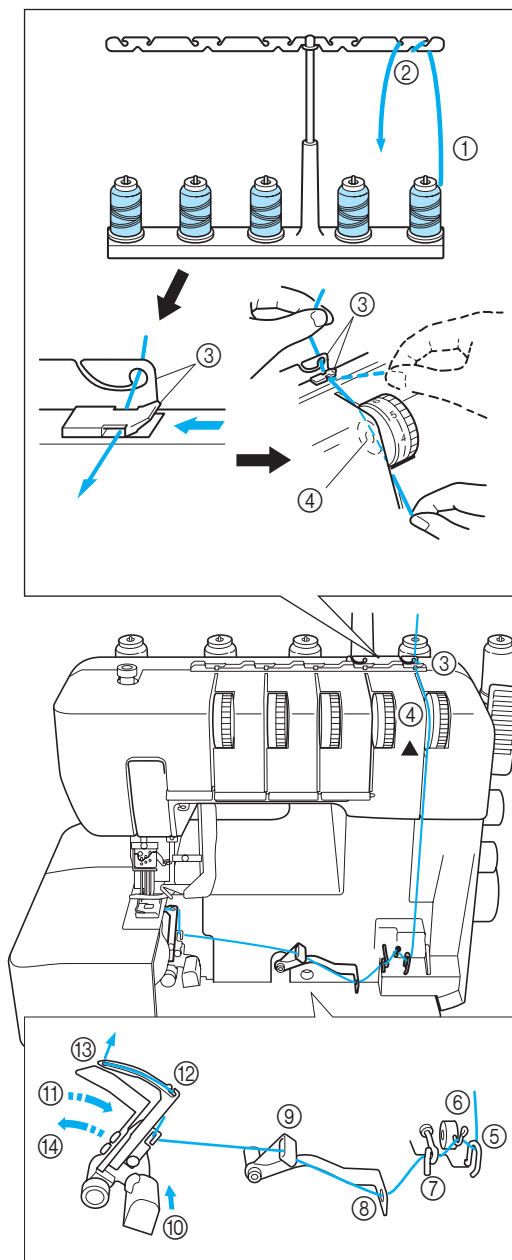

1. Open the front cover by sliding it to the right and guiding the top toward you.
2. Pull the thread off the spool and directly up through thread holder ① and thread holder ② on the thread tree, from back to front.
3. Pass the looper thread ③ as shown in the illustration.
4. Pass the thread through the tension disc ④ in the channel next to the tension dial marked with a blue ▲.
5. Guide the thread down the channel and through threading points ⑤-⑨, following the numerical order in the illustration.
6. After running the thread to ⑨, push the looper release lever ⑩ to move the looper to the right ⑪, and then run the thread through ⑫-⑬.
7. Pull about 10 cm (4 inch) of thread through the eye of the looper.
8. While pushing the looper ⑭, return the looper to its original position.
9. Close the front cover.

NOTE:

When using thick thread, such as decorative thread, as the looper thread, run the thread as shown in the illustration.

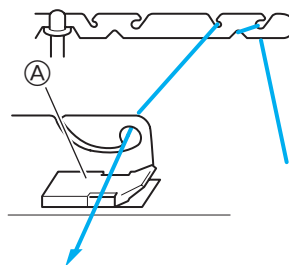

Do not run the thread through ①.

Threading the needles

■ Needle threads used by the various stitches

The triple cover stitch (three-needle, four-thread cover stitch) uses the left needle thread, center needle thread and right needle thread.

The two-needle, three-thread cover stitch (Wide) (6 mm (15/64 inch)) uses the left needle thread and right needle thread.

The two-needle, three-thread cover stitch (Narrow) (3 mm (1/8 inch)) uses the center needle thread and right needle thread.

The chain stitch uses the center needle thread.

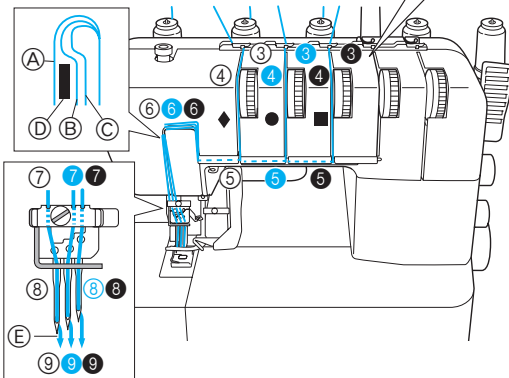
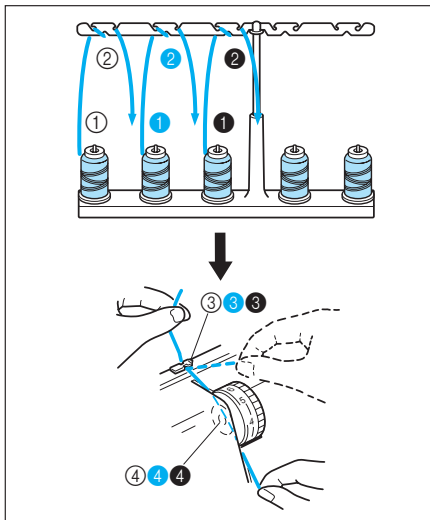

- A To left needle
- B To center needle
- C To right needle
- D Branching plate
- E Pull about 6 cm (about 2-1/2 inches) of thread through the eye of the needle.
- 9-9-9 Front to back

Threading the left needle

Run the thread in the sequence illustrated, following the yellow numbers and ◆ marks next to the threading points. (①-⑨)

Threading the center needle

Run the thread in the sequence illustrated, following the green numbers and ● marks next to the threading points. (①-⑨)

Threading the right needle

Run the thread in the sequence illustrated, following the pink numbers and ■ marks next to the threading points. (①-⑨)

⚠ CAUTION

When threading the needles, always thread in the following order: left needle, center needle and right needle.

1. Pull the thread off the spool and directly up through thread holder ①①① and thread holder ②②② on the thread tree, from back to front.
2. Pass each thread through ③③③, shown in the illustration.
3. Pass the thread through the tension disc ④④④ in the channel next to the tension dial.
4. Guide the thread down the channel and across through threading points ⑤⑤⑤-⑧⑧⑧ next to the color marks, following the numerical order in the illustration.
5. Pass the thread through the eye of the needle, front to back.

Attaching/Removing the top cover spreader and top cover thread guide

■ Attaching the top cover spreader and top cover thread guide

1. Turn the handwheel so that the line on the handwheel <A> is aligned with the line on the machine.

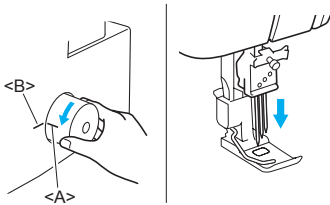

2. Squeeze the grip of the top cover spreader to spread the tips, and then, from the right side, clamp the mount of the top cover spreader onto the top cover drive shaft.

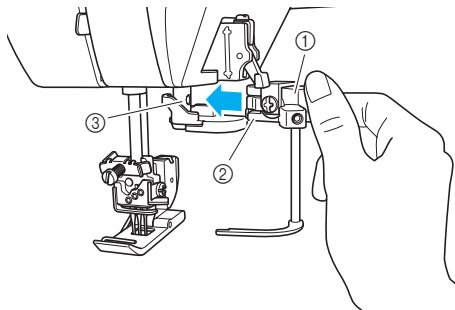

- ① Grip of top cover spreader
- ② Mount of top cover spreader
- ③ Top cover drive shaft

3. Insert the top cover thread guide into the slot in the top cover thread guide mount.

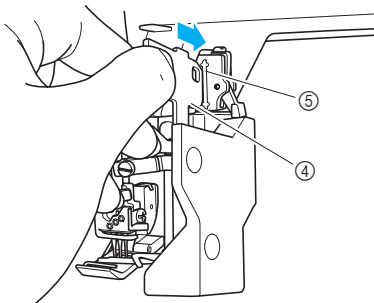

- ④ Top cover thread guide
- ⑤ Slot

■ Removing the top cover spreader and top cover thread guide

1. Turn the handwheel so that the line on the handwheel is aligned with the line on the machine.

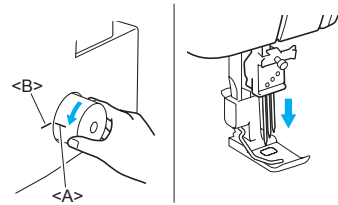

2. Press the lever on the top cover thread guide mount, and then remove the top cover thread guide.

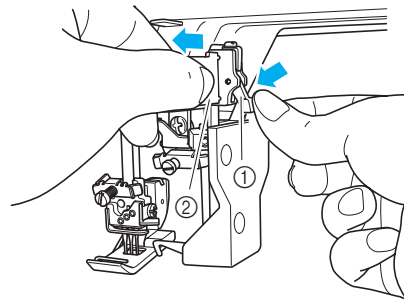

- ① Lever
- ② Top cover thread guide

3. Squeeze the grip of the top cover spreader to spread the tips, and then remove the mount of the top cover spreader from the top cover drive shaft.

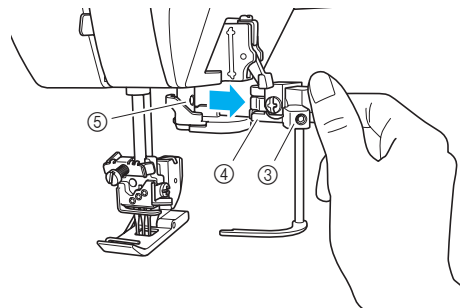

- ③ Grip of top cover spreader
- ④ Mount of top cover spreader
- ⑤ Top cover drive shaft

Threading the top cover spreader

NOTE:

Thread the top cover thread after first sewing a cover stitch seam.

■ Needle threads used by the various stitches

The triple top cover stitch (three-needle, five-thread) uses the left needle thread, center needle thread and right needle thread.

The top cover two-needle, four-thread cover stitch (Wide) (6 mm (15/64 inch)) uses the left needle thread and right needle thread.

The top cover two-needle, four-thread cover stitch (Narrow) (3 mm (1/8 inch)) uses the center needle thread and right needle thread.

Run the thread in the sequence illustrated, following the purple color and the numbers next to each threading point.

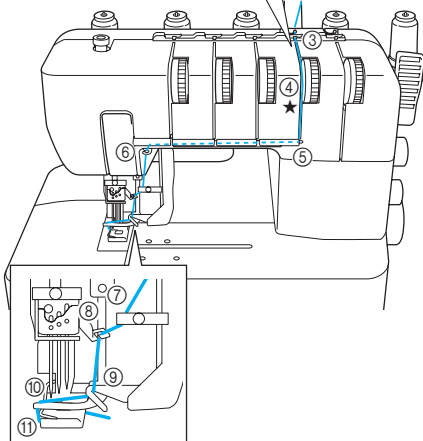
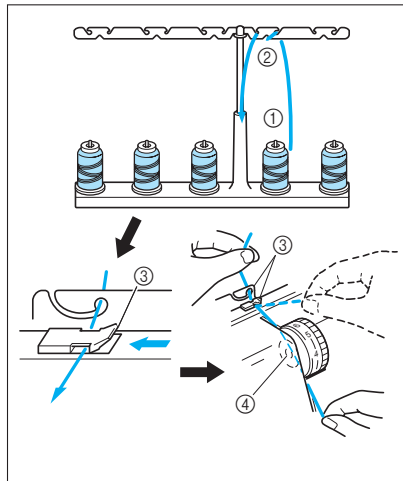

1. Pull the thread off the spool and directly up through thread holder ① and thread holder ② on the thread tree, from back to front.
2. Pass each thread through ③, shown in the illustration.
3. Pass the thread through the tension disc ④ in the channel next to the tension dial marked with a purple ★.
4. Guide the thread down the channel and across through threading points ⑤-⑨ next to the color marks, following the numerical order in the illustration.
5. Turn the handwheel counterclockwise to move the point of the top cover spreader completely to the left.
6. Thread the point of the top cover spreader as shown in the illustration ⑩.

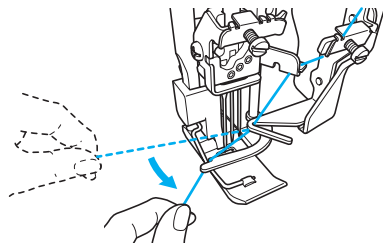

7. Pass the top cover thread under the presser foot, from left to right, as shown in the illustration ⑪, and then lower the presser foot.

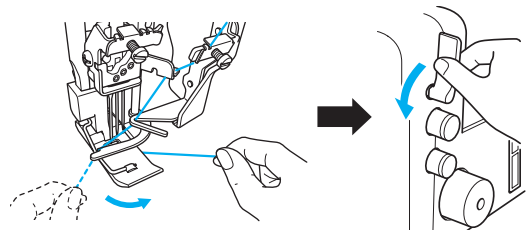

8. Turn the handwheel counterclockwise 2 to 3 times to check that the top cover thread forms stitches. After checking the stitching, use scissors to cut any excess thread, for example, if the top cover thread is too long or the top cover thread became tangled.

NOTE:



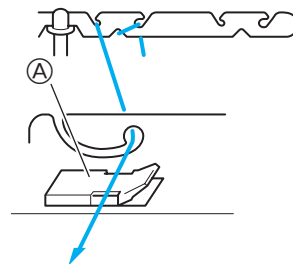



When using thick thread, such as decorative thread, as the top cover thread, run the thread as shown in the illustration.



Do not run the thread through ①.

CHAPTER 5

TYPE OF STITCHES COMPARISON CHART



Type of stitch	Number of needles	Number of threads	Thread tension dial					Stitch	Model	
			Left needle	Center needle	Right needle	Top cover thread*	Looper thread		Cover stitch	Top cover stitch
Triple cover stitch	3	4	2-5	2-5	2-5	/	2-5		✓	✓
Cover stitch (Wide)	2	3	3-5	-	3-5	/	2-5		✓	✓
Cover stitch (Narrow)	2	3	-	3-5	3-5	/	2-5		✓	✓
Chain stitch	1	2	-	2-5	-	/	2-5		✓	✓
Triple top cover stitch	3	5	3-5	3-5	3-5	3-5	3-5		/	✓
Top cover stitch (Wide)	2	4	3-5	-	3-5	3-5	3-5		/	✓
Top cover stitch (Narrow)	2	4	-	3-5	3-5	3-5	3-5		/	✓

* Top cover stitch model only.

NOTE:

The thread tension dial settings listed above are based on a stitch length of 3 and a differential feed ratio of 1.0. Since the settings may differ depending on the types of fabric and thread used, be sure to check the thread tension.

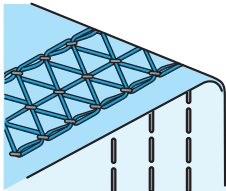
■ Triple cover stitch

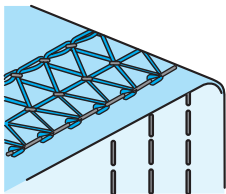
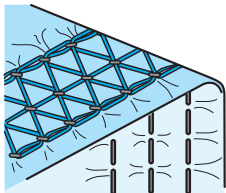
	 Stitching direction	<p>Balanced tension</p> <p>The needle thread sews a straight seam on the surface of the fabric, and the looper thread forms loops on the back.</p>
		<p>Needle thread is too loose.</p> <p>Turn the needle thread tension dial to a higher number to increase the tension, or turn the looper thread tension dial to a lower number to decrease the tension.</p>
		<p>Needle thread is too tight.</p> <p>Turn the needle thread tension dial to a lower number to decrease the tension, or turn the looper thread tension dial to a higher number to increase the tension.</p>

■ Cover stitch (Wide/Narrow)

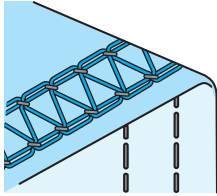
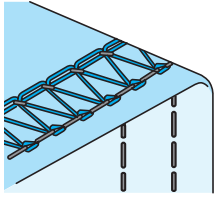
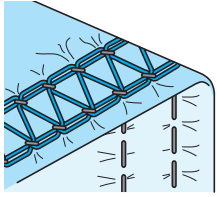
	<p>Balanced tension</p> <p>The needle thread sews a straight seam on the surface of the fabric, and the looper thread forms loops on the back.</p>
	<p>Needle thread is too loose.</p> <p>Turn the needle thread tension dial to a higher number to increase the tension, or turn the looper thread tension dial to a lower number to decrease the tension.</p>
	<p>Needle thread is too tight.</p> <p>Turn the needle thread tension dial to a lower number to decrease the tension, or turn the looper thread tension dial to a higher number to increase the tension.</p>

■ Chain stitch

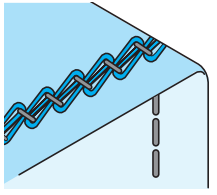
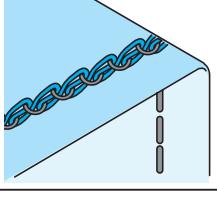
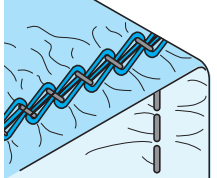
	<p>Balanced tension</p> <p>The needle thread sews a straight seam on the surface of the fabric, and the looper thread forms loops on the back.</p>
	<p>Needle thread is too loose.</p> <p>Turn the needle thread tension dial to a higher number to increase the tension, or turn the looper thread tension dial to a lower number to decrease the tension.</p>
	<p>Needle thread is too tight.</p> <p>Turn the needle thread tension dial to a lower number to decrease the tension, or turn the looper thread tension dial to a higher number to increase the tension.</p>

■ Triple top cover stitch

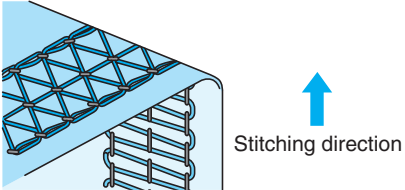
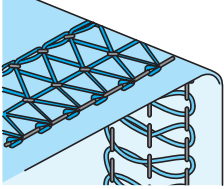
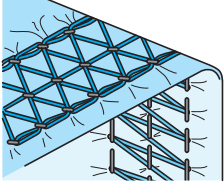
	<p>Balanced tension</p> <p>The top cover thread sews a straight seam on the surface of the fabric, and the looper thread forms loops on the back.</p>
	<p>Top cover thread is too loose.</p> <p>Turn the top cover thread tension dial to a higher number to increase the tension, or turn the needle thread tension dial to a lower number to reduce the tension.</p>
	<p>Top cover thread is too tight.</p> <p>Turn the top cover thread tension dial to a lower number to decrease the tension, or turn the needle thread tension dial to a higher number to increase the tension.</p>

■ Top cover stitch (Wide/Narrow)

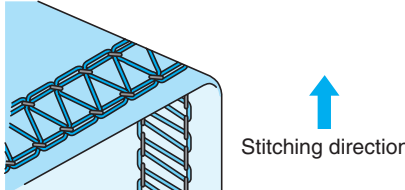
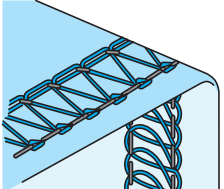
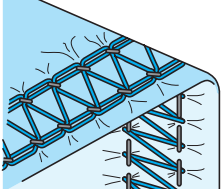
	<p>Balanced tension</p> <p>The top cover thread sews a straight seam on the surface of the fabric, and the looper thread forms loops on the back.</p>
	<p>Top cover thread is too loose.</p> <p>Turn the top cover thread tension dial to a higher number to increase the tension, or turn the needle thread tension dial to a lower number to reduce the tension.</p>
	<p>Top cover thread is too tight.</p> <p>Turn the top cover thread tension dial to a lower number to decrease the tension, or turn the needle thread tension dial to a higher number to increase the tension.</p>

CHAPTER 6 SEWING

⚠ CAUTION

While the machine is in operation, pay special attention to the needle location. In addition, keep your hands away from all moving parts such as the needle and handwheel, otherwise injuries may occur.

Sewing flat fabric (for example, trial sewing)

1. Raise the presser foot, and then place the fabric at the needle drop position.

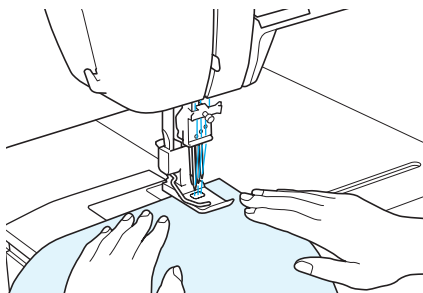

2. Lower the presser foot, turn the handwheel toward you a few times by hand, and then lightly step on the foot controller to start sewing.

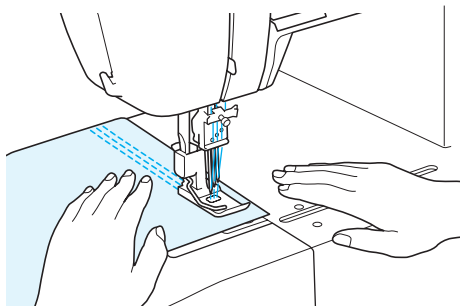

NOTE:

When starting to sew after threading or changing thread colors, the thread will be on top of the presser foot. In order to sew without incident, place fabric under the presser foot. Turn hand wheel toward you a few times by hand. Thread will be anchored into the fabric. Cut the threads shown to continue to sew.

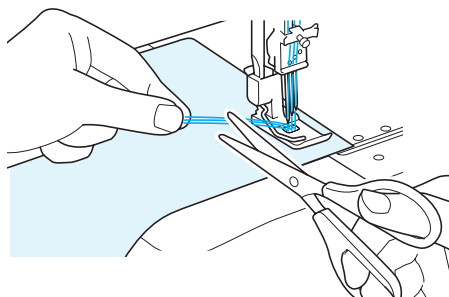

NOTE:

When sewing stretch fabrics, adjust the differential feed and check that the desired finish is achieved.

Removing the fabric from the machine (Cover stitch model)

1. By hand, turn the handwheel toward you until the needle is at its highest position.

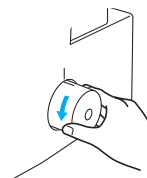

2. Raise the presser foot.

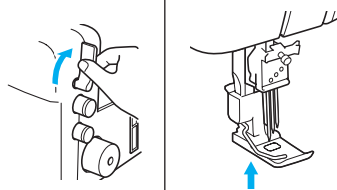

3. Slowly pull the fabric in the direction of the arrow.

NOTE:

Be sure to pull the fabric to the back.

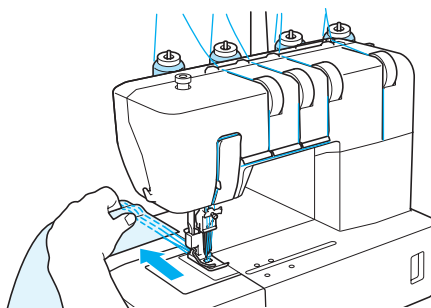

4. Cut the needle threads, which come out from the surface of the fabric.

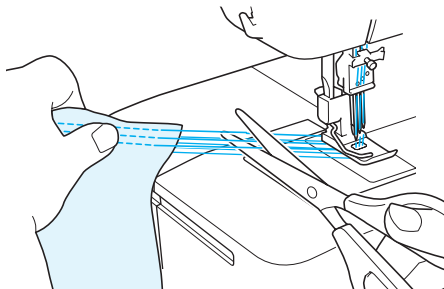

5. Slowly pull the fabric in the direction of the arrow so that the ends of the needle threads are pulled to the back of fabric.

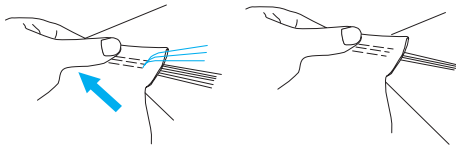
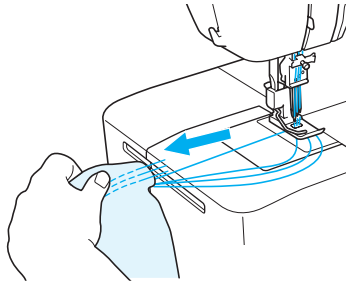

6. Cut the looper thread.

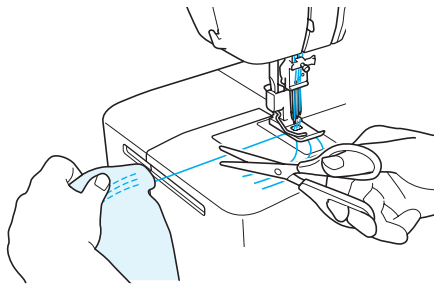

NOTE:

We recommend using scissors to cut the looper thread. Scissors can also be used to cut the machine threads.

7. Pull all threads at the back of the fabric. Tie all threads together and cut.

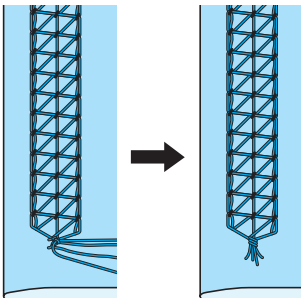

Removing the fabric from the machine (Top cover stitch model)

1. By hand, turn the handwheel toward you until the needle is at its highest position.



2. Raise the presser foot.

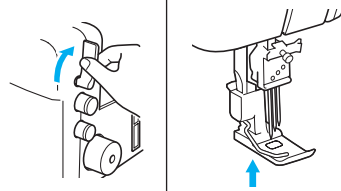

3. Slowly pull the fabric in the direction of the arrow.

NOTE:

Be sure to pull the fabric to the back.

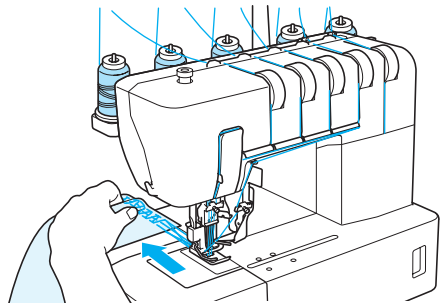

4. Cut the needle threads, which come out from the surface of the fabric.

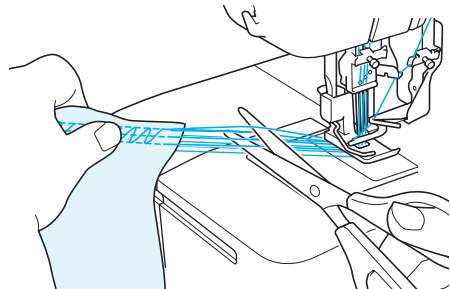

5. Slowly pull the fabric in the direction of the arrow so that the ends of the needle threads are pulled to the back of fabric.

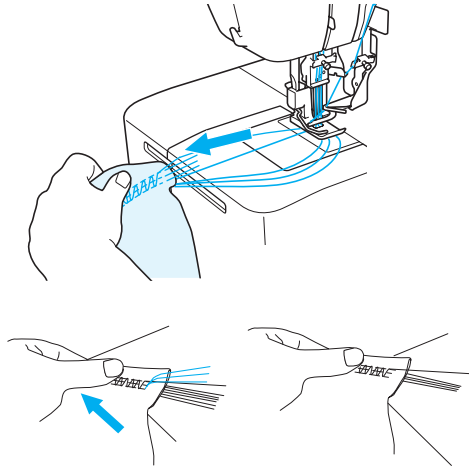

6. Cut the top cover thread and looper thread to lengths that can be tied.

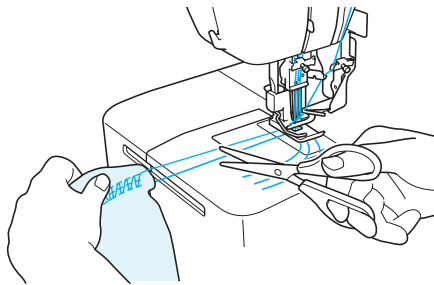

NOTE:
We recommend using scissors to cut the looper thread. Scissors can also be used to cut the machine threads.

NOTE:
You can sew all the way to the edge of a fabric and also sew off the edge of the fabric to create a chain of thread. Cut thread after any length of chain has been stitched.

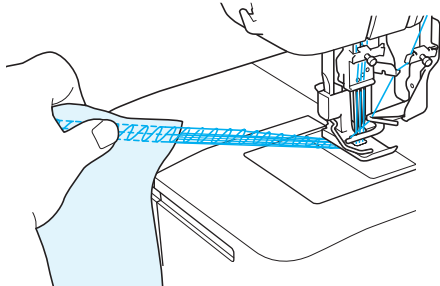

7. Use a pointed object, such as a needle, to push in the top cover thread from the surface of the fabric, and then pull the thread at the back of the fabric.

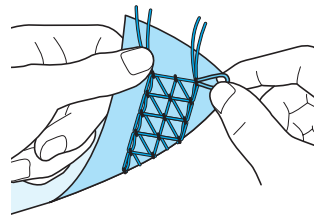
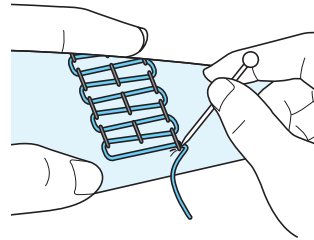

8. Pull all threads at the back of the fabric. Tie all threads together and cut.

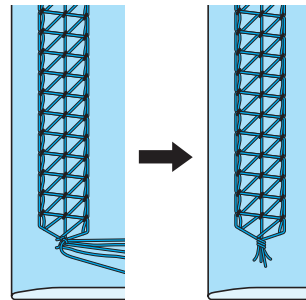

Sewing a cover stitch

1. Determine how much of the fabric will be folded up.
2. Fold up the fabric the desired amount, and then iron it in place.
3. Use a ruler to measure, and then use a fabric marker to mark the top of the fabric to sew where the edge of the folded fabric is positioned.
4. Place the bottom of the presser foot onto the top of fabric, and then check that the drawn mark is just barely to the right of the left needle.
5. Sew exactly on the mark.
6. After sewing is finished, refer to "Removing the fabric from the machine (Cover stitch model)" on page 24 for details on taking care of the threads.

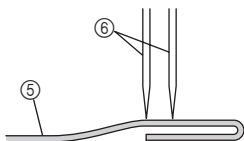
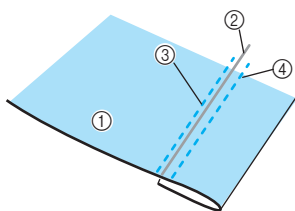

- ① Fabric (surface)
- ② Mark drawn with fabric marker
- ③ Left needle (just barely on the left side of the mark)
- ④ Right needle
- ⑤ Fabric
- ⑥ Needle

Sewing tubular garments (for example, cuffs)

■ Without free-arm sewing

1. Raise the presser foot, insert the fabric as shown in the illustration, lower the presser foot, and then begin sewing.

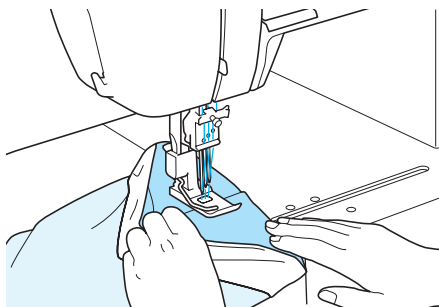

2. Finish sewing by overlapping about 4 cm (1-1/2 inch) of the beginning and end of the stitching.

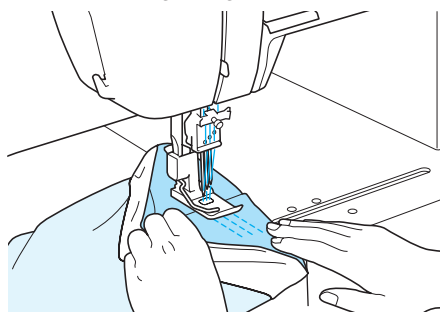

NOTE:

When sewing tubular garments, overlapping the beginning and end of the stitching by about 4 cm (1-1/2 inch) will prevent the seam from tearing.

3. Remove the fabric as explained in "Removing the fabric from the machine (Cover stitch model)" and "Removing the fabric from the machine (Top cover stitch model)" on pages 24 and 25.

■ With free-arm sewing

1. Remove the bed extension.

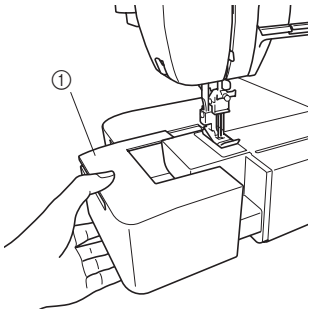

① Bed extension

2. Position the fabric, and start sewing.

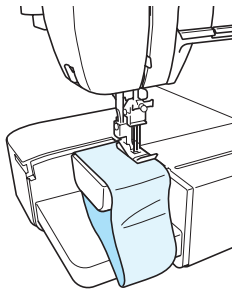

- (1) Raise the presser foot, insert the fabric as shown in the illustration, lower the presser foot, and then begin sewing.
- (2) Finish sewing by overlapping about 4 cm (1-1/2 inch) of the beginning and end of the stitching.

Stabilizing the beginning and end of stitching

To sew with the beginning and end of stitching stabilized, finish the beginning and end of stitching with a 4-cm-square piece of scrap fabric as described below.

■ Beginning of stitching

1. Raise the presser foot, and then insert the scrap fabric. Lower the presser foot, turn the handwheel toward you a few times by hand, and then lightly step on the foot controller to start sewing.
2. When nearing the end of stitching for the scrap fabric, stop the machine. Insert the fabric as shown in the illustration below, and then lightly step on the foot controller to start sewing.

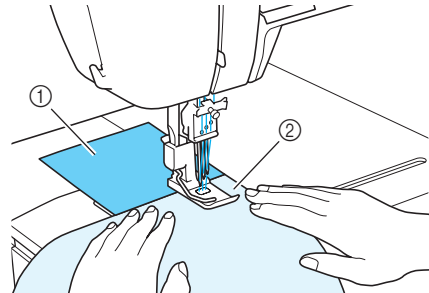

① Scrap fabric
② Fabric

■ End of stitching

1. When nearing the end of stitching for the fabric, stop sewing. Insert the scrap fabric as shown in the illustration below, and then finish sewing.
2. Sew into the scrap fabric, stop the machine, and then use scissors to cut the threads between the fabrics and scrap fabrics.

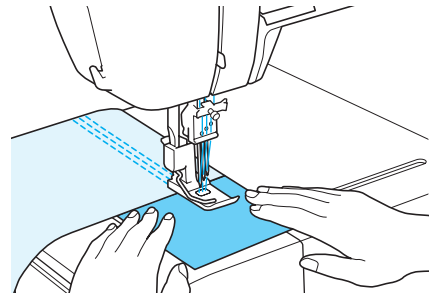

CHAPTER 7

TROUBLESHOOTING

This sewing machine is designed for trouble-free operation. However, the following chart indicates trouble which may occur if basic adjustments are not made properly.

Trouble	Cause	Remedy
1. Does not feed	Presser foot pressure too loose	Turn the pressure adjustment screw clockwise to increase the presser foot pressure. (See page 11.)
2. Needles break	1. Needles bent, or needle tip blunt	Replace with new needle. (See page 12.)
	2. Needles incorrectly installed	Install needles correctly. (See page 12.)
	3. Material pulled forcibly	Do not press or pull material too hard when sewing.
3. Threads break	1. Improper threading	Thread correctly. (See pages 15-18, 20.)
	2. Thread tangled	Check spool pin, thread holders, etc., and remove tangled thread.
	3. Thread tension too tight	Adjust the thread tension. (See pages 11.)
	4. Needles incorrectly installed	Install needles correctly. (See page 12.)
	5. Wrong needle used	Use correct needle. 130/705H recommended (See page 12.)
4. Skipped stitches	1. Needle bent, or needle tip blunt	Replace with new needle. (See page 12.)
	2. Needle incorrectly installed	Install needle correctly. (See page 12.)
	3. Wrong needle used	Use correct needle. 130/705H recommended (See page 12.)
	4. Improper threading	Thread correctly. (See pages 15-18, 20.)
	5. Presser foot pressure too loose	Turn the pressure adjustment screw clockwise to increase the presser foot pressure. (See page 11.)
5. Stitches not uniform	Thread tensions not adjusted properly	Adjust the thread tension. (See pages 11.)
6. Fabric puckers	1. Thread tension too tight	Decrease thread tension when sewing lightweight or fine material. (See pages 11.)
	2. Improper threading or thread tangled	Thread correctly. (See pages 15-18, 20.)

CHAPTER 8 MAINTENANCE

Cleaning

⚠ CAUTION

Turn off the machine before cleaning.

Periodically clean out dust, trimmed fabric and thread with the included cleaning brush.

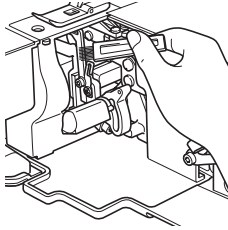

SPECIFICATIONS

■ Cover stitch model

Use	Fine to heavy materials
Sewing speed	Maximum 1,000 stitches per minute
Stitch width	6 mm / 3 mm
Stitch length (pitch)	2 mm to 4 mm (5/64 to 5/32 inch)
Needle bar stroke	29 mm (1 1/8 inches)
Presser foot	Free presser type
Presser foot lift	5 mm to 6 mm (3/16 to 15/64 inch)
Needle	SCHMETZ 130/705H (90/#14)
Number of needles and threads	Convertible to two/three/four threads
	Convertible to one/two/three needles
Stitches	One-needle, two-thread double chain stitch
	Two-needle, three-thread cover stitch (Wide) (6 mm (15/64inch))
	Two-needle, three-thread cover stitch (Narrow) (3 mm (1/8inch))
	Three-needle, four-thread triple cover stitch (6 mm (15/64inch))
Machine net weight	7.6 kg
Machine dimensions	396 mm (W) × 297 mm (D) × 358 mm (H) (Approx. 16 (W) × 12 (D) × 14 (H) inches)
Needle set 130/705H	

■ Top cover stitch model

Use	Fine to heavy materials
Sewing speed	Maximum 1,000 stitches per minute
Stitch width	6 mm / 3 mm
Stitch length (pitch)	2 mm to 4 mm (5/64 to 5/32 inch)
Needle bar stroke	29 mm (1 1/8 inches)
Presser foot	Free presser type
Presser foot lift	5 mm to 6 mm (3/16 to 15/64 inch)
Needle	SCHMETZ 130/705H (90/#14)
Number of needles and threads	Convertible to two/three/four/five threads
	Convertible to one/two/three needles
Stitches	One-needle, two-thread double chain stitch
	Two-needle, three-thread cover stitch (Wide) (6 mm (15/64inch))
	Two-needle, three-thread cover stitch (Narrow) (3 mm (1/8inch))
	Three-needle, four-thread triple cover stitch (6 mm (15/64inch))
	Two-needle, four-thread top cover stitch (Wide) (6 mm (15/64inch))
	Two-needle, four-thread top cover stitch (Narrow) (3 mm (1/8inch))
	Three-needle, five-thread triple top cover stitch (6 mm (15/64inch))
Machine net weight	7.6 kg
Machine dimensions	396 mm (W) × 297 mm (D) × 358 mm (H) (Approx. 16 (W) × 12 (D) × 14 (H) inches)
Needle set 130/705H	

Please visit us at <http://support.brother.com/> where you can get product support and answers to frequently asked questions (FAQs).